

Flow Watch Instruction Manual

Model: F6

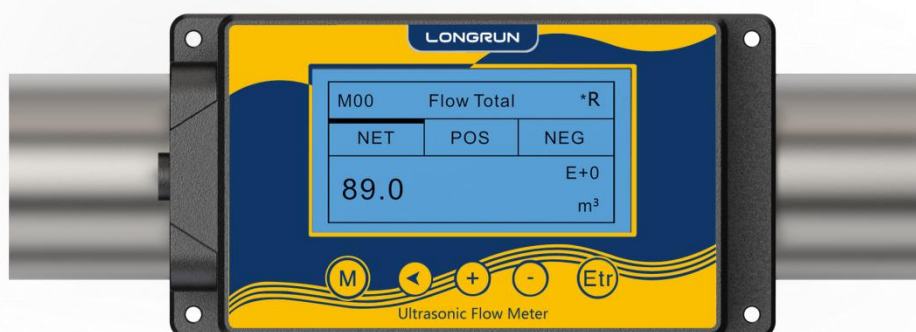

LONGRUN

Longrun Industrial Instrument Co.,Ltd

Preface

Thanks for purchasing the product!

The User's Manual covers functions, settings, wiring and troubleshooting methods of this flowmeter. Please carefully read this manual before use.

After reading the manual, please keep it in a proper place for reference when you operate the flowmeter.

Notes

Any modifications concerning function update in this manual will not be notified.

This manual has been carefully checked, if you find anything improper or any errors, please contact the vendor.

If there are any differences between the flowmeter and its descriptions in this manual, please take the final product as standard.

DO NOT fully or partially reprint or reproduce this manual.

Version

2022-V1

Warnings

For your safety, please carefully read the following safety warnings before use.

Contents

1.1	Product Liabilities and Quality Assurance	- 4 -
1.2	Descriptions of the Flow Meter	- 5 -
Chapter II	Descriptions of the Flow Meter	- 5 -
2.1	Delivery Scope	- 5 -
2.2	Measuring Principle	- 6 -
2.3	Application Scope	- 6 -
Chapter III	Electrical Connections	- 7 -
3.1	Safety Prompts	- 7 -
3.2	Electrical Cables used for the Flow Meter	- 7 -
3.3	Connecting electrical cables	- 8 -
3.4	Transmitter Connections	- 9 -
Chapter IV	Operation Panel and Quick Start	- 10 -
4.1	Power on	- 10 -
4.2	Keyboard Operation	- 10 -
4.3	Quick Start	- 11 -
5.2	Pipe Design and Selection	- 13 -
5.3	Transducer Installation	- 16 -
Chapter VI	Operation	- 21 -
6.1	Common Functions	- 21 -
6.2	Description of Operation Menus	- 25 -
Chapter VII	Common Faults and Troubleshooting	- 31 -
Chapter VIII	Communication Interface and Communication Protocol	- 32 -
Appendix.	Related Measurement Database	- 39 -

Copyrights and Data Protection

Content of this file has been carefully checked. We don't promise that the content is totally correct and completely identical with the latest version.

Content of this file and related products are under protection of China's copyright laws. Without authorization in writing of the Company, please DO NOT try to reproduce, transfer, transcribe or translate any parts of the flowmeter including the source code to any languages or computer language in any forms or through electronic, electromagnetic, optical or other means.

Without authorization in writing of the Company, please DO NOT reproduce, copy, reprint, translate or transfer the manual or part of it to any electronic or readable media.

The designations and signs shown on the product are the registered trademark or trademark of the Company. All other trademarks, product designations or company names quoted herein are only used for identification and belong to the property of their respective owners.

Exception Clauses

The manufacturer shall bear no responsibilities for any consequences caused by the product in use, which include penalties arising from any direct or indirect accidents or indirect losses.

The exception clauses shall be invalid if the manufacturer's actions are intentional or the manufacturer has culpable negligence. According to applicable laws, it is not allowed to confine implied warranties of the product, or it is not allowed or it confines the compensation of some kind, and these rights are applicable to you, under such cases, the above exception clauses or confinement may partially or completely inapplicable to you.

As for each purchased product, related product files and the manufacturer's sales terms are applicable.

As for the content of these exception clauses, the manufacturer should reserve the right to make any corrections in any form, at any time or for any reason with no need to issue any notifications in advance, and shall bear no responsibilities in any forms arising from the corrections described herein

1.1 Product Liabilities and Quality Assurance

The purchaser should judge by himself whether the flowmeter is applicable or not, and shall bear related responsibilities. The manufacturer would bear no responsibilities for any consequences arising from the purchaser's misuse of the flowmeter. The purchaser may lose the rights for quality assurance if the flowmeter or the system is installed or operated in a wrong way. In addition, the corresponding "Standard Terms of Sale" is also applicable, and shall be the basic conditions of the Sales Contract.

Information about this file

To avoid any injuries or any damages to the flowmeter, please DO carefully read this file and DO comply with local standards, safety rules and accident prevention rules.

If you can't understand this file, please ask the manufacturer or the vendor for help. As for any property loss or personal injury arising from your misunderstandings, the manufacturer would bear no related responsibilities.

With this manual, you could set up correct operating conditions of this flowmeter to ensure safety and efficiency in use.

In addition, special notes and safety measures will be marked through the following symbols.

Convention of graphic symbols

The following symbols will help you better understand the file.



Warning!

This symbol indicates electrically related safety prompts.



Caution!

Please DO pay attention to this symbol. Any slight negligence may cause severe health hazard and may damage the flowmeter or related equipment and facilities in operation.



Prompts!

The symbol indicates related important information for operation.

1.2 Descriptions of the Flow Meter



Caution!

For your safety, please carefully read the following safety instructions before use. With this manual, you could set up correct operating conditions of this flowmeter to ensure safety and efficiency in use.

Only certified personnel who have received related training are allowed to install, use, operate and maintain this flowmeter.

Caution!



1. When using the flowmeter in inflammable media, please take measures to prevent from fire or explosion.
2. When operating the flowmeter in hazardous environment, DO follow the correct operation steps.
3. When removing the flowmeter, please follow the fluid OEM's safety instructions to avoid splashing.
4. Pay attention to the flowmeter's probe. Even a minor scratch or incision would influence its accuracy.
5. To get the optimum efficiency, the longest calibration period could not exceed two years.

Chapter II Descriptions of the Flow Meter

2.1 Delivery Scope



Prompts!

PROMPTS

Please carefully check whether the packing case is damaged or loaded/unloaded in an improper way or not. If it is damaged, please notify the delivery man and the manufacturer or the consignor and describe the damage in details.



Prompts!

PROMPTS

Please check the goods you received with the packing list.



Prompts!

PROMPTS

Please check the flowmeter's nameplate and conform whether the scope of supply is identical with your order. Check whether the power information on the nameplate is correct or not; if not, please contact the manufacturer or the dealer.

2.2 Measuring Principle

This series of ultrasonic flowmeter is an industrial time-difference type ultrasonic flowmeter. It applies the latest industrial-level PFGA, which extremely improves the signal sampling frequency and bubble tolerance rate; the self-developed TGA technology makes it be capable of dealing with more complex logic and calculation to provide more accurate and faster measurements, and ensures the flowmeter could endure non-continuous bubbles or impurities within 5 sec. In addition, it could be installed and operated in a convenient way with no need to break the pipe or cut off the fluid or stop work.

Time-difference type ultrasonic measurement indicates determining the fluid flow along the average velocity with the time difference between two ultrasonic signals transmitting downstream or upstream in the same stroke.

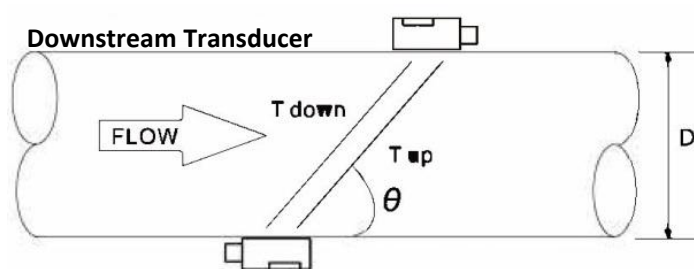

$$V = \frac{MD}{\sin 2\theta} \times \frac{\Delta T}{T_{up} - T_{down}}$$

Upstream Transducer

In which:

- v Flow Velocity
- M Ultrasonic reflections
- D Pipe diameter
- θ Included angle between ultrasound signal and fluid
- Tup Time that downstream transducer sends signal to upstream
- Tdown Time that upstream transducer sends signal to downstream

$$\Delta T = T_{up} - T_{down}$$

2.3 Application Scope

It mainly applies for measuring the flow of homogeneous medium fluid in the following fields:

Domestic wastewater flow measurement, crude oil flow measurement, cementing slurry flow measurement, oily sewage flow measurement in oil fields, water injection flow measurement in oil wells, raw water flow measurement in rivers and reservoirs, tap water flow measurement, process flow measurement of petrochemical products, industrial circulating water flow measurement, water consumption measurement in production, mineral slurry flow measurement, pulp flow measurement, chemical flow measurement, circulated cooling water flow measurement, generating coil cooling water flow

measurement (super small diameter), juice flow measurement, milk flow measurement, and so on.

Chapter III Electrical Connections

3.1 Safety Prompts



Warning!

DO cut off the power before any electrical connections. Please pay attention to the power supply data on the nameplate.



Caution!

Please strictly comply with local professional health and safety regulations. Only trained personnel are allowed to operate the electrical equipment.



Prompts!

Please check the nameplate and confirm whether the goods are identical with your order or not. Check whether the power supply on the nameplate is correct or not; if not, please contact the manufacturer or the vendor.



Warning!

As specified, the meter must be connected to the protective ground terminal to protect operators from electric shock.

Transducer housing should be grounded according to national electrical codes, and the most efficient way for it is to directly connect it to the ground.

3.2 Electrical Cables used for the Flow Meter

Prompts about signal cables



Prompts!

As for signal cables with double shield, efficient grounding of the shield layer could greatly eliminate the disturbance on the measured value in transmission.

Please pay attention to the following prompts:

Please place cables firmly.

It is allowed to place signal cables in water or soil.

Insulating materials should be flame retardant complying with EN 5062, IEC60322-1 or related standards.

Signal cables shouldn't be exposed or contain plasticizer, and shall be flexible at a low

temperature.

Internal shield should be connected through the multi-stranded drain wire.

It is recommended to use "RVVP" shield cables as electrical connection cables. The power cord should be connected from the hole on one side and the signal cable should come out from the hole on the other side.

Special shield cable connecting the transducer and the transmitter should be placed far away from strong electromagnetic to avoid interference; DO NOT place it with HV cables. Special cables should be minimum with no coiling to eliminate the distributed inductance.

3.3 Connecting electrical cables



Warning!

Signal cables and power cables must be connected while the power is off.



Warning!

As specified, the meter must be connected to the protective ground terminal to protect operators from electric shock.



Warning!

As for the meters to be used in hazardous areas, please pay attention to the safety and technical prompts as specified in the professional explosion-proof instructions.



Caution!

Please strictly obey the local occupational health and safety regulations. Only trained personnel are allowed to operate on electrical equipment.



Warning!

Voltage difference is not allowed between the measuring transducer and the housing or protective ground cable of the electronic system.

The measuring transducer must be well grounded according to related standard DESIGN CODE OF INSTRUMENT GROUNDING (HT/T 20513-2014).

The ground conductor shall not transmit any disturbance voltage.

The ground conductor is not allowed to connect other electrical equipment.

3.4 Transmitter Connections



3.4.1. Power supply

Please pay attention to the power supply. Please connect related power supply according to the symbols of connecting terminals.

3.4.2. Transmitter connections

Once the flowmeter is installed at the designated place as required, you can start connections.

Please connect the cable according to the wiring mark, the specific explanation is as follows:

DC+	Power supply DC10-24V +
DC-	Power supply DC10-24V -
IOUT+	4-20mA Output
IOUT-	
A	RS485 Communication (Modbus)
B	
In2+	Temperature transducer positive outlet
In2-	Temperature transducer negative outlet
GND	Temperature transducer negative outlet



Warning!

Please ensure that the flowmeter is connected with the power off, and ensure that it has been reliably grounded before use.

3.4.3 Power on

When switching the power on for the first time, the flowmeter will run automatically according to the parameters you put last time (the meter is calibrated before leaving factory). After the flowmeter is installed and powered on, you can check its status in M04 menu; if it displays “*R”, it indicates that the flowmeter is running normally.

If you use the flowmeter in a new environment, you need to input related parameters. Any parameters you input would be kept in its memories forever till you correct them again. If you need to adjust its installation position or the position of the transducer, you need to input and set related parameters again of the flowmeter to ensure normal use.

DO always finish all tasks when running. No matter in any displays, tasks including measurement and output should be finished as usual.

Chapter IV Operation Panel and Quick Start

4.1 Power on



Warning!

Please check the meter is correctly installed or not before power on, including:

Connecting the power supply as specified;

Please check the electrical connection of the supply power is correct or not.

4.2 Keyboard Operation

4.3.2 Descriptions

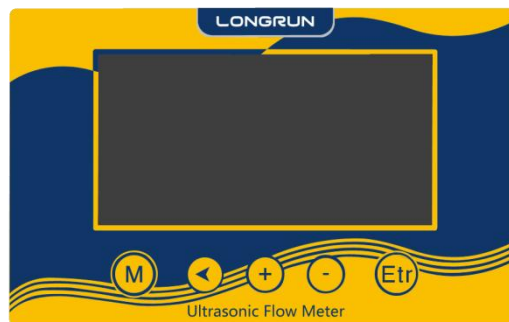

Key M : Used to switch between the six categories of menus.

Key < : Go back to the previous menu/delete the previous input data

Key + : Page up/Previous option/Previous number

Key - : Scroll down/Next option/Next number

Key Etr: Enter the main menu/confirm the current input and options



Note:

In normal conditions, press [Enter] key to alter the parameters; if you can't alter related parameters after pressing [Enter] key, it is possible that the system protection function is enabled to avoid touching by mistake. Please enter M54 menu and input the codes (if not available, it would be the ex-factory codes) to enable the correction authority.

4.3 Quick Start

Basic settings

We will take PVC pipe for example. Related parameters: Outer diameter 20mm, wall thickness 4mm, and material is PVC with no lining and the medium is room temperature water.

Step1. Pipe Size setting

M10 Pipe settings

Input the outer diameter and wall thickness.

Note:

This model standard pipe size range is from DN15 to DN 40.

(Min inner diameter is 12mm)

M10	Pipe settings	*R
Size	M.	
OD	20.0	mm
thk	4.0	mm

Step2. Pipe material setting

M10 Pipe settings

Press [+/-] key to switch pipe materials

Press [Enter] for settings.

Select pipe material and the following materials are available in the menu:

0.PVC

1.CS carbon steel

2.SSP stainless steel pipe

3.CIP cast-iron pipe

4.DIP ductile iron pipe

5.Copper

6.Alu aluminum pipe

7.ACP asbestos-cement pipe

8.FPG fiberglass pipe

9.Others (If you choose Item 9, please input the material velocity.)

M10	Pipe settings	*R
Size	M.	
M.	0.PVC	
Other	3200	m/s

Step 3. Measurement liquid setting

M12 Medium

Select liquid you measure on site and following liquid types are available in the menu:

- 0. Water
- 1. Other ((If you choose others, please input the liquid velocity)

M12	Medium	*R
Type	VIS	
Option	0.Water	
Other	1482.0	m/s

Step 4. Transducer type

M13 Transducer

No need to set here

M13	Transducer	*R
Type	Method	Mode
Option	TT02S	
	(No need set)	

Step 5. Installation methods of transducers

M13 Transducer

No need to set here

M13	Transducer	*R
Type	Method	Mode
Option	1.Z	
	(No need set)	

Step 6. Installation spacing of transducers

After setting, M14 menu will display the installation spacings of transducers.

Please install transducers correctly according to the spacings displayed.

M14	INSTL Spacing	*R
Value	20.0	mm

5.2 Pipe Design and Selection

The following should be taken into account when selecting a pipe:

5.2.1 Installation Environment

It's better to install the flowmeter indoors; if you have to install it outdoors, you should take measures to avoid direct sunlight or rainwater.

The flowmeter shall be installed away from high temperature, thermal radiation from equipment or corrosive gas.

Ultrasonic flowmeters can't be installed nearby motors, transformers or other power sources that are easy to cause electromagnet interference. DO NOT install ultrasonic flowmeters nearby frequency converters or DO NOT connect it with the distributing cabinet of frequency converters to avoid interference.

In convenience for installation and maintenance, keep sufficient space around the flowmeter.

5.2.2 Support of Flow Meter

Avoid installing the flowmeter on pipes with mechanical vibrations. If you have to install it there, DO take shock absorption measure. You could install a hose for transition, or set support points with absorbing pads on the pipe at 2DN in both upstream and downstream of the flowmeter. Try not to install the flowmeter on the longer overhead pipes because the sagging of pipes would cause leakage between the flowmeter and the flanges. If you have to do it, you must set support points on the pipe at 2DN in both upstream and downstream of the flowmeter.

5.2.3 Requirements on Liquid-receiving Material

The ultrasonic flowmeter could measure single-medium liquid flow; The same medium could be divided into three specifications (low temperature, high temperature and superhigh temperature), different flowmeters should be used for different temperatures.

5.2.4 Dangerous Conditions

You could select the flowmeter with an explosion-proof housing, and intrinsic safety explosion-proof flowmeter with intrinsic safety design circuit to ensure its safety and flame-retardant operation. Each flowmeter should have a nameplate clearly identifying its certifications. Please DO install and use the flowmeter according to the explosion-proof grade and protection grade as shown on the nameplate.



Caution!

DO ensure that the flowmeter is filled. DO NOT make the liquid flow downwards vertically, or it may have bubbles.



Caution!

To ensure measurement accuracy of the flowmeter, try to satisfy the following requirements on the length of straight pipe sections installed nearby the flowmeter: upstream >20D, downstream>10D.



Caution!

Before ultrasonic flow meter installation, please set the parameters according to the method of [Quick start] section of this manual, and obtain the installation spacing L value of the sensor from M14 menu.

The mounting distance is the distance between the end faces of two clamp on transducers.

Try not to disturb the upstream flow distribution. Ensure no valves, elbows or triplets; try to install the control devices or throttles in the downstream if any, so as to ensure sufficient pipe flow at the measurement point, details are shown below:

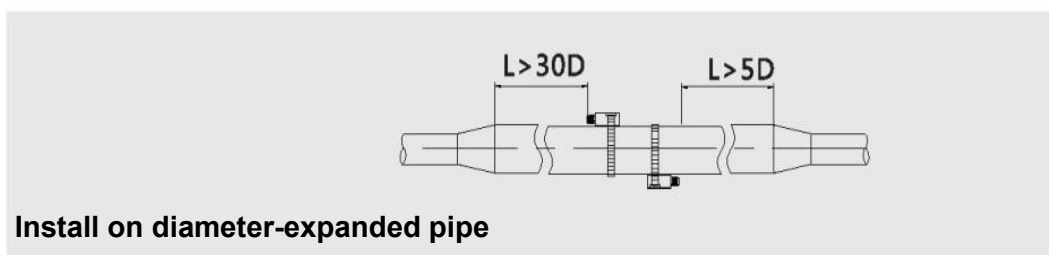
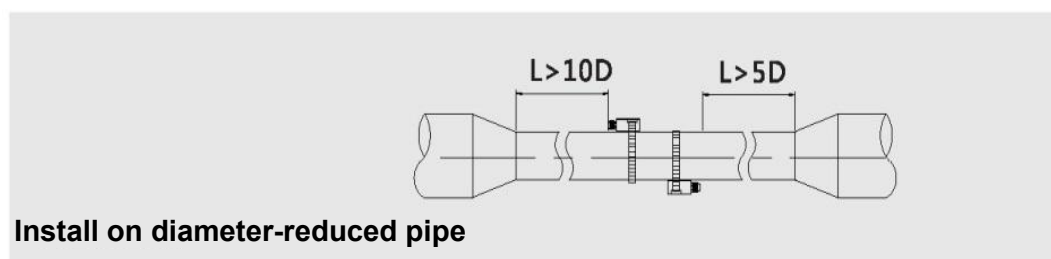
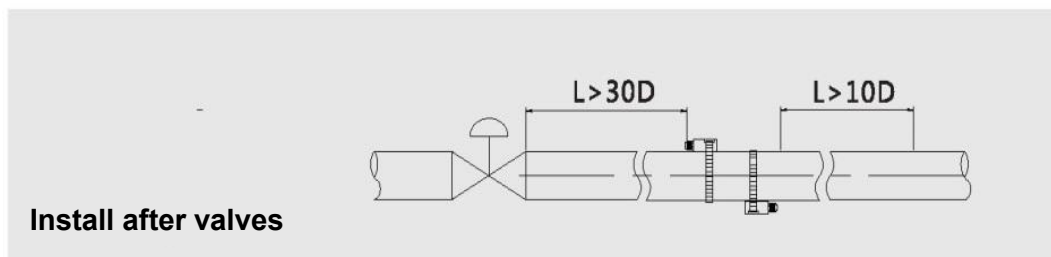
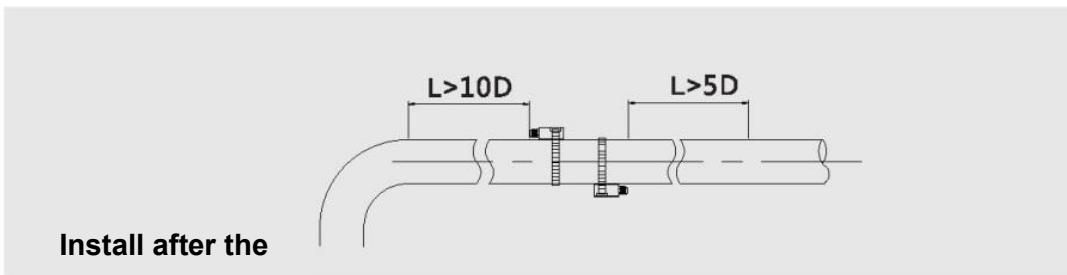
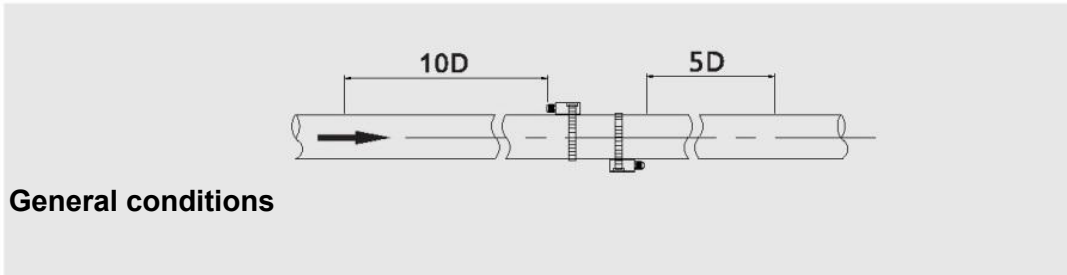

5.3 Transducer Installation

5.3.1 Transducer Installation Steps

1. Please set parameters of M10 and M12 according to the actual situation on site, and adjust the end distance of the sensor according to the installation distance of M14. As shown in the figure below. **Do remember to apply the coupling compound on the surface of transducers.**

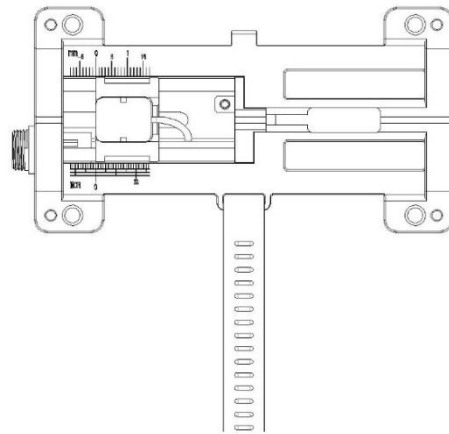

2. Fix the flow meter bottom part on the pipe on with the rubber strap supplied with the product.

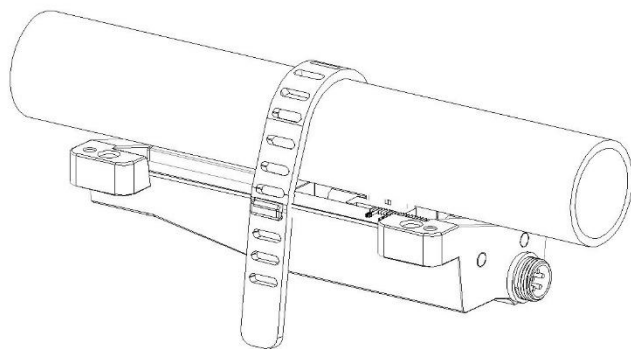

3. Insert the four fixing brackets of flow meter top part into the corresponding holes.

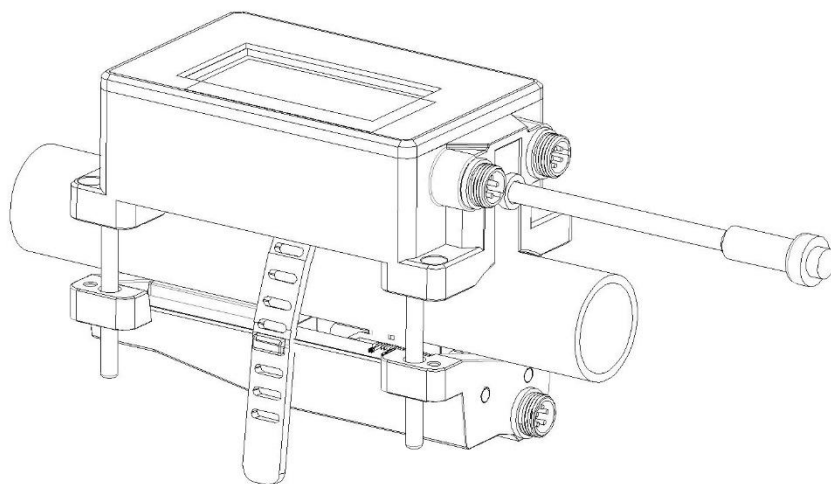

4. Lock screws to fix both top and bottom part of flow meter.

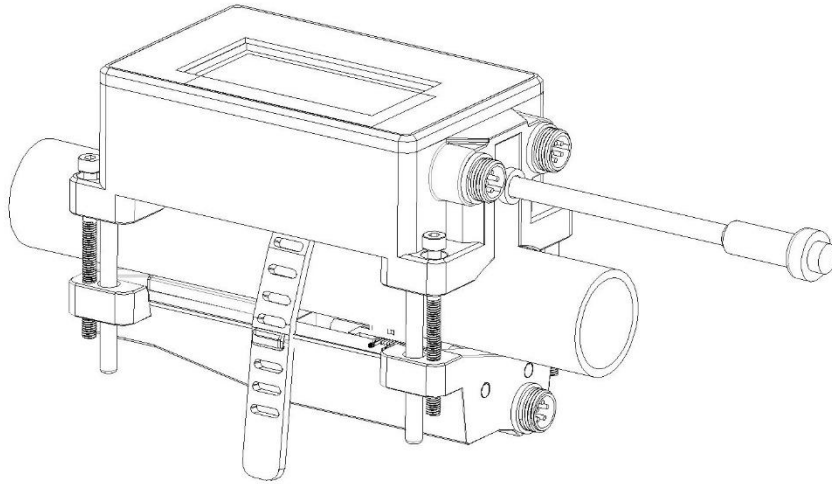

5. Insert the aviation plug of the upper cover into the corresponding position of the bottom cover and tighten it. Then the installation is complete.

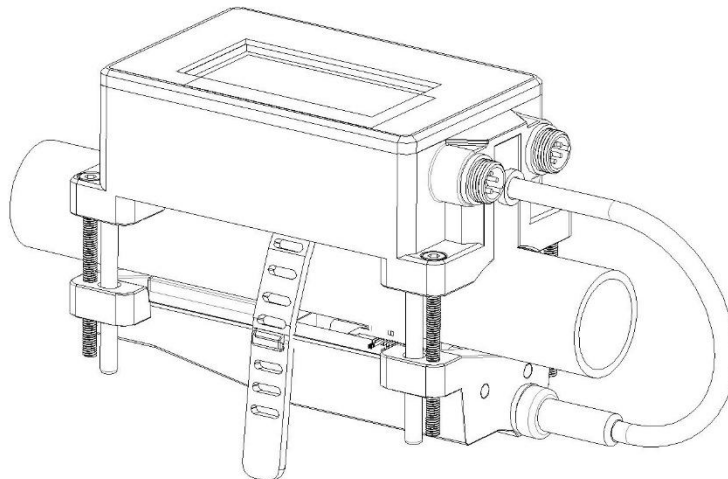

5.3.2 Confirmation on Installation Quality

Enter M04 menu

M04			Status	*R
Signal	Sound	Time		
UP	DN	Q		
85	85	99		

M04			Status	*R
Signal	Sound	Time		
Vel.	0.0	m/s		
Ratio	0.0%			

M04			Status	*R
Signal	Sound	Time		
Total	0.0	us		
Delta	0.0	ns		

Signal strength (UP/DN indicates upstream/downstream transducer):

Ultrasonic Flow Meter applies 00.0-99.0 to indicate corresponding signal strength, the bigger the value, the stronger the signal strength. In normal operation, the signal strength of the upstream/downstream transducer should be >85 as required. If the signal strength is less than 80, please check whether the transducer is correctly installed or not again, check whether the coupling compound is applied properly or not; check whether the upstream/downstream transducer is on the same horizontal plane or not, and check whether the two transducer’s installation spacing is identical with the value shown in M14 or not.

Q value (Signal quality):

Q value (Signal quality) indicates the degree of received signals’ quality; the flowmeter applies 00.0-99.0 to indicate relative signal quality, the bigger the value, the better the signal quality. In normal conditions, the signal quality (Q value) should be over 80.

Sound velocity:

Vel. value indicates the sound velocity and the actual sound velocity measured by the flowmeter. Under normal conditions, it should be close to the sound velocity shown in M12 menu. If the difference is too big, you should check the installation settings and whether it is properly installed or not.

Transmission time (Ratio):

Transmission time is used for checking whether the installation spacing of two transducers is correct or not; If they are installed correctly, the transmission time should be $100\pm 3\%$.

Total transmission time (Unit: us) and time difference (Unit: ns):

When the time difference fluctuates too greatly, the flow and flow rate would change greatly, it indicates that the signal quality is poor, which may be caused by bad pipe conditions, improper installation or parameter errors. Under normal conditions, the fluctuation of time difference should be less than $\pm 20\%$. But when the pipe diameter is too small or the flow rate is extremely low, its fluctuation would exceed the normal value a little.

Chapter VI Operation



Note:

The flowmeter would be calibrated and debugged before leaving factory, and its parameters would be set accurately.

Please carefully read the instructions if necessary.

Non-professionals are not allowed to operate the flowmeter.

6.1 Common Functions

6.1.1 How to Judge its Operating Status

If it displays "*R", it indicates the flowmeter works normally.

If it displays "D", it indicates the flowmeter is carrying out auto gain adjustment before measurement, it is normal most of the time. If it lasts for a long time, it indicates that the flowmeter fails.

If it displays "E", it indicates that the flowmeter can't receive sound wave signals. Please check the connections and installation of transducers. As for more information, please refer to "ERRORS".

6.1.2 Low Flow Cut off

M21 menu is the low flow cut menu. The system considers the flow whose absolute value is less than this value as "0", so you can set this parameter to avoid false accumulation of measurement errors of the flowmeter when the actual flow is "0". In general, this parameter is 0.03m/s. When the flow is more than the low flow cut value, the low flow cut value has nothing to do with the measurement result and will have no influences on it.

6.1.3 Zero Point Setting

Any flowmeter has a relative zero point. That is to say, when you judge the flow is zero but the flowmeter doesn't display zero, this value is called zero point. Of course, as for any flow meters, zero point is objective, but its value is controllable. If zero point is not "0", it will cause measurement errors. Moreover, the smaller the measured physical quantity, the greater the error caused by it. Only when zero point is reduced to a certain degree as compared with the measured physical quantity, the error caused by it could be ignored. As for ultrasonic flowmeter, when the flow is smaller, error caused by zero point couldn't be

ignored. You need to set zero point to improve the accuracy for small flow measurement. At the time, you need to cut zero point on site.

Cut zero steps:

M22 menu-Cut-1. Yes, it displays "success" if zero point is cut. and the flowmeter would return to M01 menu.

Reset zero steps:

M22 menu--Reset-1. Yes

6.1.4 Flow Meter K Factor

Meter factor indicates the specific value of actual flow and the display value of the flowmeter. For example, the actual flow at the measurement point is 3 and the flowmeter displays 2.99, then the meter factor is $3/2.99$. Under perfect measurement status, the optimum meter factor is "1". However, it's hard to make all flowmeters have the same factor in batch production and also because of the changeable environment on site, it's impossible to ensure the meter factor of all flowmeters is "1".

Therefore, each flowmeter would be calibrated before leaving factory to get its meter factor, which is called K Factor.

You also could calibrate the flowmeter in service on site through M26 menu.

6.1.5 System Protection

System protection is mainly to avoid abnormal operation of flowmeter in installation or operation because of touching by mistake. When system protection is enabled, you could view the flowmeter but can't correct any parameters.

You could enable or disable this function in M54 menu. You need to enter passcode to activate the function or make alterations.

6.1.6 Current Loop Output

The current loop output accuracy is 0.1%. It is programmable and you can set several output modes like 4~20mA and 0~20mA in M23 menu.

In M32 menu, 4mA/20mA is the minimum/maximum limit value. For example, the flow range in a pipe is 0~1000m³/h, you only need to input 0 and 1,000 respectively in M32 menu. If the flow range is -1,000 ~ 0 ~ 2,000m³/h, and 20 ~ 4 ~ 20mA output is used while

not considering the flow direction, you could set 1000 and 2000 as the minimum and maximum limit values respectively in M32 menu.

However, when 0-4-20mA output is used while considering the flow direction, you should consider two different conditions; when the flow direction is reverse, the output current is 0~4mA; when it is forward, the output current is 4~20mA.

“Check” in M32 menu is used for check whether the current loop has been “calibrated” or not.

6.1.7 Frequency (Option output)

The flowmeter is provided with frequency signal output function. Transient flow is indicated by frequency. Users can reset the frequency scope of the frequency signal and the transient flow that it indicated if necessary.

For example: The flow scope in a pipe is 0~5,000m³/h, it is required to output the corresponding frequency signal 100~1,000Hz, you can carry out the following settings:

M33-Scope-Lower limit (Lower limit frequency signal flow value), enter 0;

M33-Scope-Upper limit (Upper limit frequency signal flow value), enter 5,000;

M33-Mode-Frequency, enter 100, 1,000;

M33- Mode -Options, select "a. Flow";

OCT common wiring diagram:

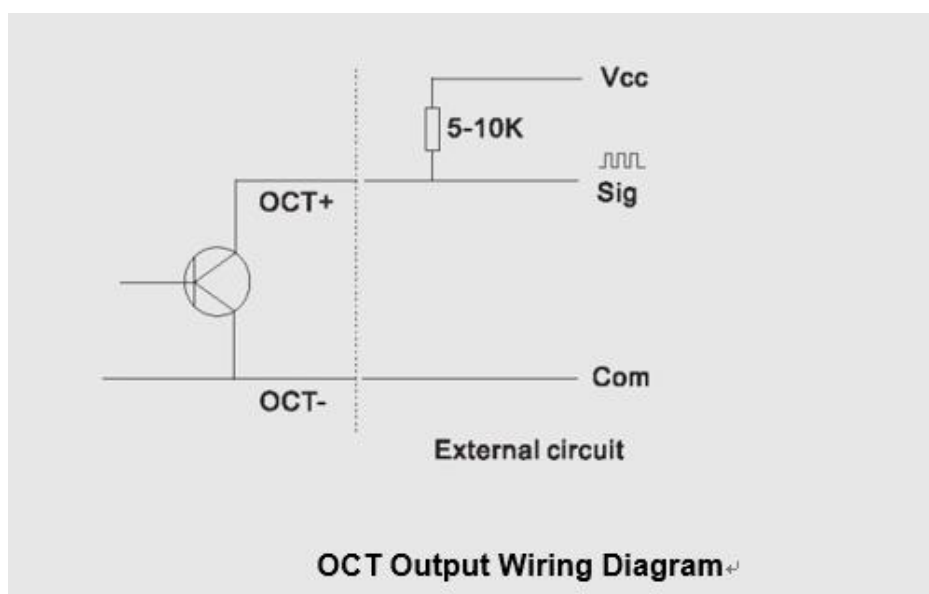

6.1.8 Alarms (Option output)

Switch output alarm signal is generated through switching on/off OCTs or relays and output to the external circuit, it is generated under the following conditions:

1. Transducers can't receive ultrasound signals;
2. Ultrasound signals that transducers received are too poor;
3. The flowmeter is not under normal operation;
4. The flow is reversed;
5. The analogue output exceeds 100% of the measuring range;
6. The frequency signal exceeds 120% of the measuring range;
7. Transient flow exceeds the settings (use software alarm to set the range of flow. There are two software alarms, which are Alarm #1 and Alarm #2T respectively.

How to set? For example 1: It requires the relay outputs alarm signals when the transient flow exceeds 300~1,000m³/h, settings are as follows:

- (1) Menu 34, Relay Settings-Options-Alarm 1#.
- (2) Menu 34, Alarm 1#, lower limit 300;
- (3) Menu 34, Alarm 1#, upper limit 1,000;

6.1.9 Product Serial Number

Each flowmeter is provided with a unique product serial number. The serial number is the unique mark for the manufacturer and users for tracing product information and management. You could view your flowmeter's serial number in M 50 menu.

Note:

Please refer to "Details about Menus" for operation of other menus.

6.2 Description of Operation Menus

6.2.1 Abbreviated codes of menus

Level One Menu	Menu Codes and Description	Details
Measurement value & status *R- System Normal *E- Signal Not Detected *D- Adjusting Gain	M00 Flow Total	Net total Positive total Negative total
	M01 Flow Rate	Flow rate & Flow velocity
	M02 Heat (Optional function)	Heat total & temperature difference (ΔT)
	M03 Cool (Optional function)	Cool total & temperature difference (ΔT)
	M04 Status	Signal strength & quality Sound velocity & Ratio Transmission total time & difference
Site information setting	M10 Pipe Settings	Pipe OD, thickness & Material
	M12 Medium Settings	Water & other liquid
	M13 Transducer setting	No need to set here
	M14 Installation Space	Installation Space
Adjustment setting	M20 Damping	

	M21 Low Flow Cut off	Low Flow Cut off Value
	M22 Zero Point Settings	Cut off Zero & Reset
	M23 Totalizer	Totalizer type setting & Reset
	M24 Temperature sensitive	Effective temperature difference
	M26 K factor setting	
	M27 Calibration	Multi points calibration (Calibration flow velocity value is fixed)
	M28 4-20mA setting	
	M29 RTD adjustment	Temperature off set
Output setting	M30 RS 485	Baud rate & Flow meter address
	M32 4-20mA	Output Mode Corresponding Range & Adjustment
	M33 OCT (frequency) - (Optional output)	Output Mode Corresponding Range & Adjustment
	M34 Relay (Aram) - (Optional output)	Output Mode Upper and lower alarm values

Unit setting	M40 System unit	Metric unit & British unit
	M41 Flow unit	Flow & Flow total unit Multiplication factor
	M42 Energy unit	Energy & Energy total unit Multiplication factor
	M43 Temperature	°F & °C
System setting	M50 SN & Software version	
	M53 Language setting	Chinese/ English
	M54 System lock & Password word	
	M55 Reset & Interface Settings	

6.2.2 Menu operation Settings

In the Primary menu state, press M to switch between the six categories of menus

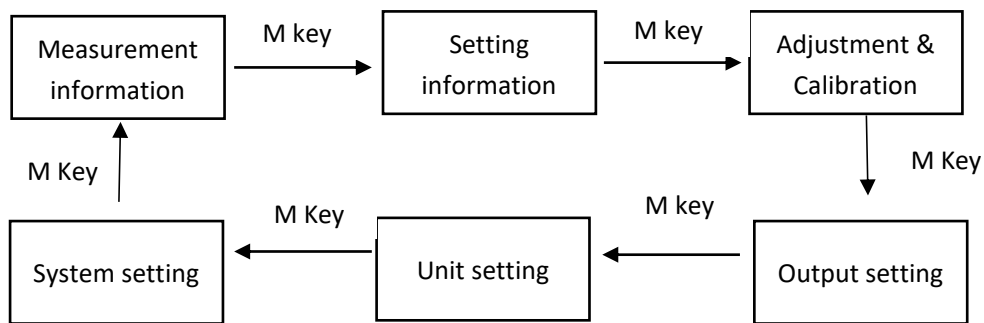

Key M : Used to switch between the six categories of menus.

Key < : Go back to the previous menu/delete the previous input data

Key + : Page up/Previous option/Previous number

Key - : Scroll down/Next option/Next number

Key Etr: Enter the main menu/confirm the current input and options

The following uses media type as an example:

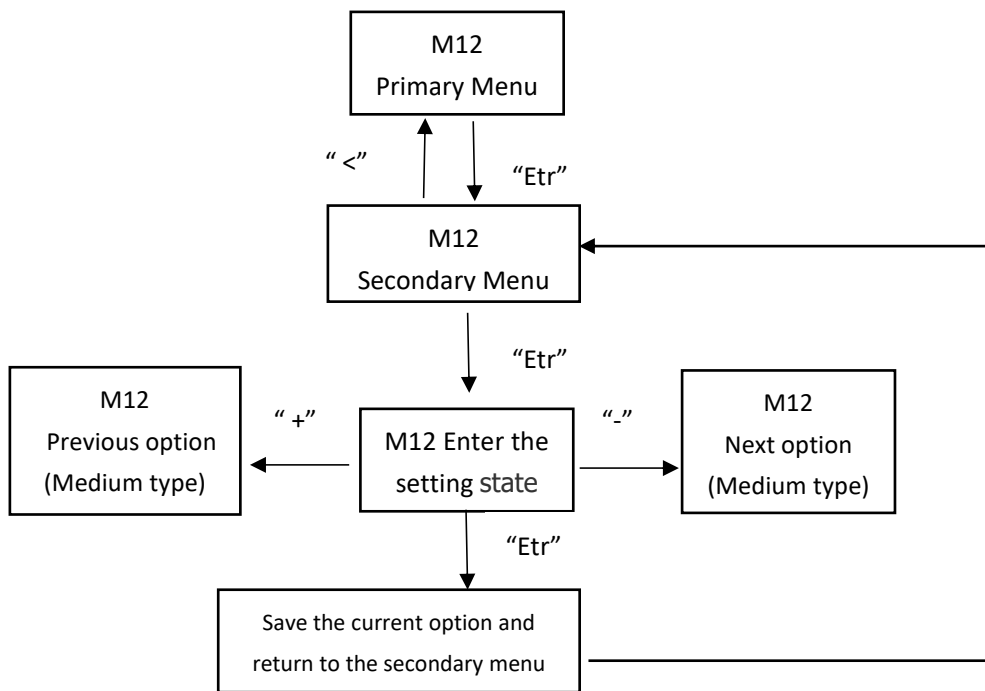

Number entering operation instructions, Take the setting of a low flow rate cut off value as an example

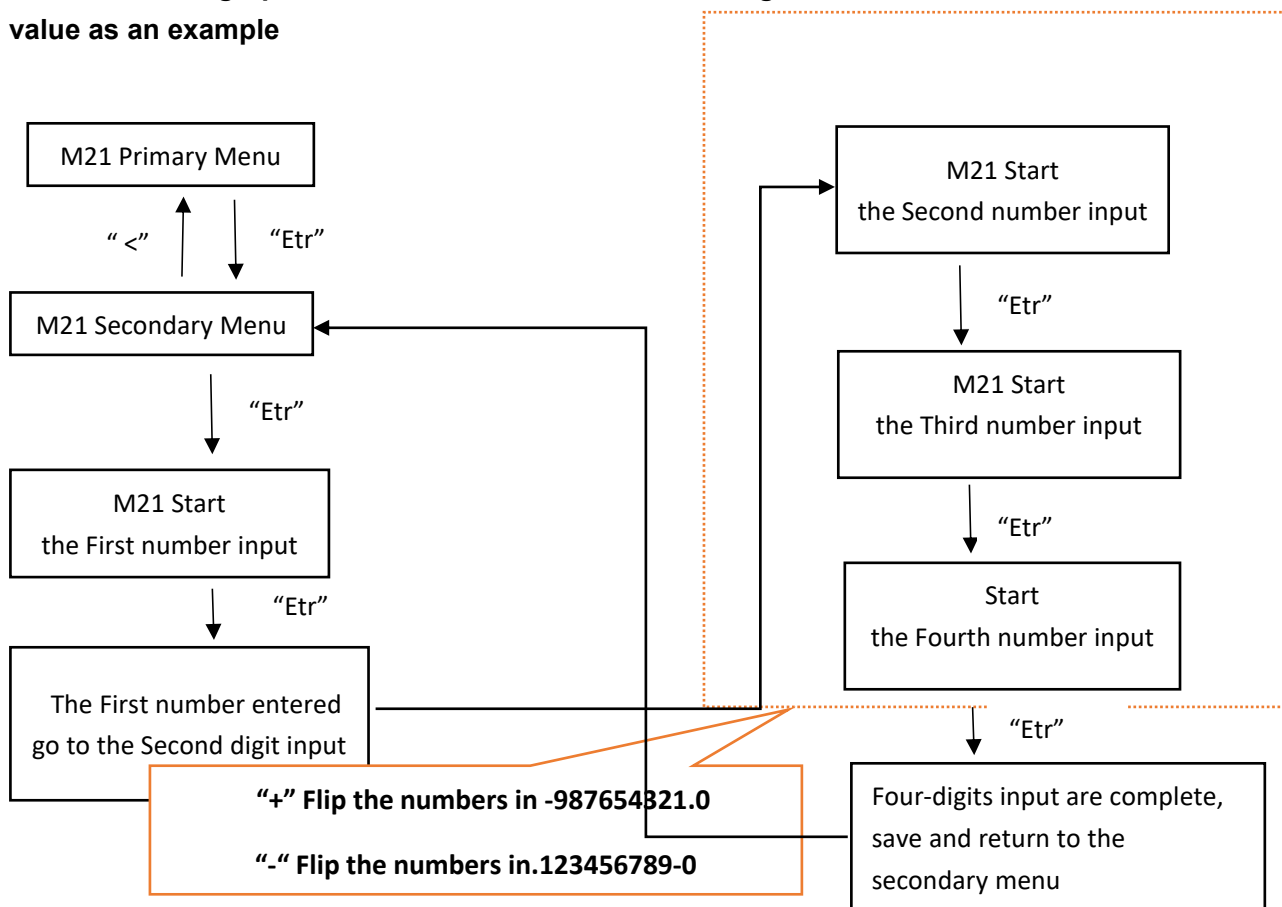

6.2.3 Menu Operation Description

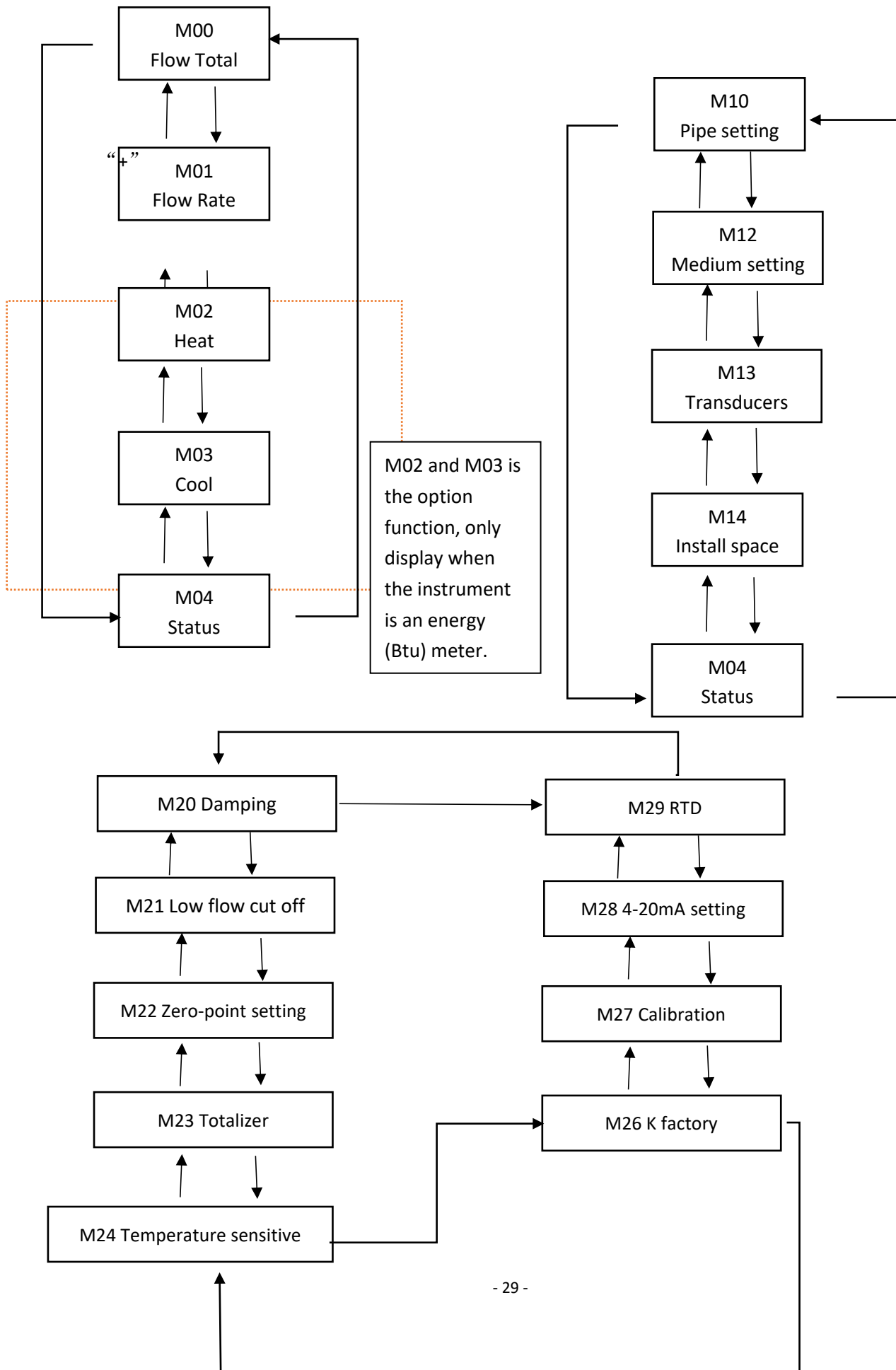

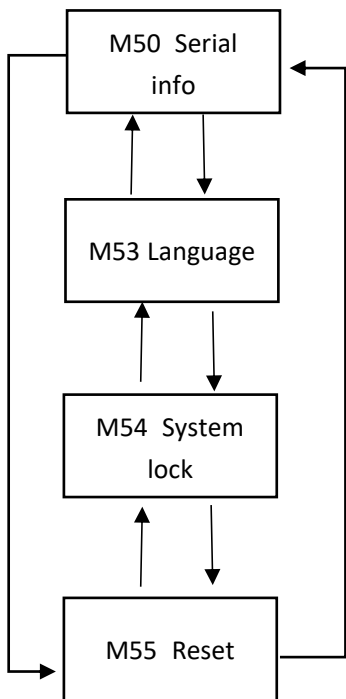
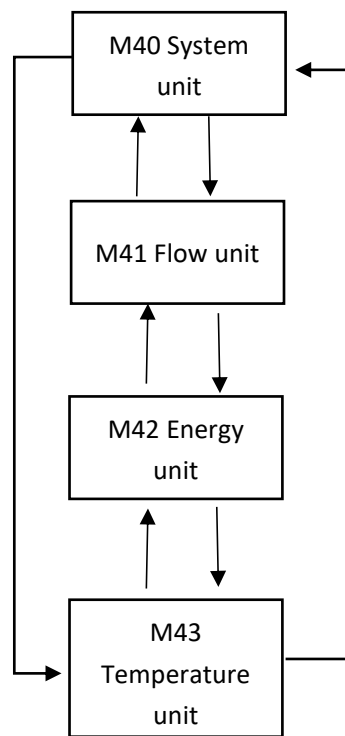
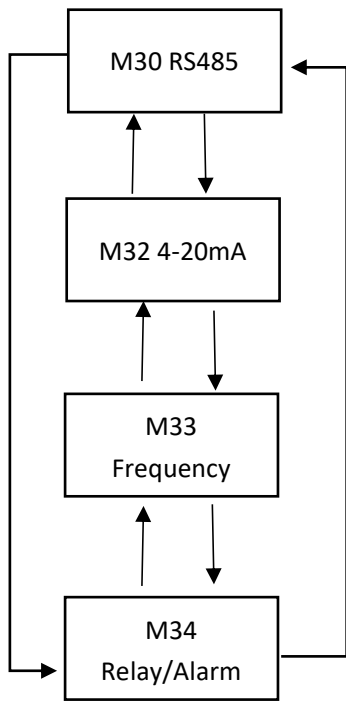

Chapter VII Common Faults and Troubleshooting



Note:

Each flowmeter would be strictly tested and checked before leaving factory. However, it would still fail to work because of incorrect operation, wrong settings or bad working conditions. The following shows the common faults happened in operation, and provides analysis and related solutions.

If you still couldn't solve the problem, please contact the manufacturer or local service provider.

Fault Causes and Troubleshooting

Code	Description	Causes	Troubleshooting
*R	System Normal	* The system runs normally	
*E	Run signal unknown	* It can't receive signals	*Check whether the transducers are installed correctly or not.
		* The installation spacing between transducers is incorrect or they are not installed on the same horizontal plane.	Check the installation parameters and slightly adjust transducers to check whether they could receive any signals or not.
		* The couplant is applied in an improper way, or there are bubbles between transducers and the pipe wall.	*Ensure that the couplant is applied in a proper way and there are no bubbles between transducers and the pipe wall.
		* There are too many scales on the inner wall of the pipe. * A new pipe lining is used.	* Paint and rust on the wall should be removed. *Remove scales or replace the pipe section with scales with a new one, or install the flowmeter at a proper place for measurement. *Measure when the lining is solidified.
*D	Gain adjustment	* The flowmeter is carrying out normal gain adjustment and is preparing for measurement	

Chapter VIII Communication Interface and Communication Protocol

8.1 General

The flowmeter is provided with an UART protocol, and you also could operate by using RS-485 Modbus. There are two basic structures you could choose for networking, i.e. only applying the analog current output method or directly applying the UART communication method of the flowmeter. The former one is applicable for replacing the old meter in the old monitoring network, while the latter is used for the new monitoring network, which has a lot of advantages like low hardware investment, reliable system operation and etc.

When directly using the UART communication for the monitoring network system, you could use the address identification code as the network address code and use the command extending set with [W] as the communication protocol.

8.2 UART Definition

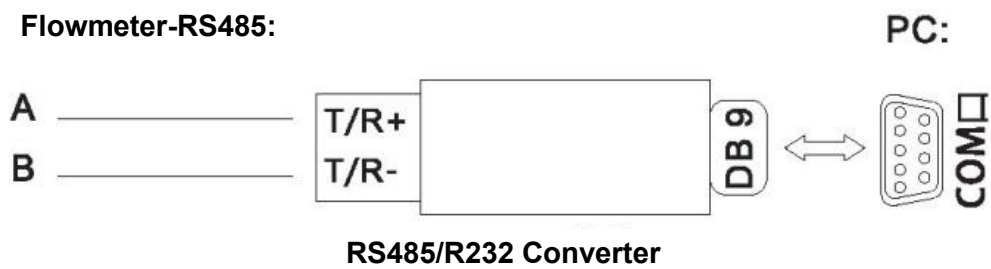

8.3 Communication Protocol and its Use

The flowmeter supports HL protocol and MODBUS protocol.

8.3.1. HL protocol

The flowmeter applies HL communication protocol. The host device would request the flowmeter to respond after sending a “command”. Asynchronous communication baud rate (Main station: computer system; secondary station: ultrasound flowmeter) is 9,600 BPS in general.

Single byte data format (10 bits): One start bit, one stop bit and eight data bits. Check bit: Non. One data character string is used for indicating the basic command, while one ENTER is used for indicating ending the command. This command is applicable for RS232 and RS485. Common commands are shown below:

Common Communication Commands

Command	Description	Data format
RFR(cr)(lf)	Return to Transient Flow	±d.dddddddE±dd(cr) Note 1
RVV(cr)(lf)	Return to Transient Velocity	±d.dddddddE±dd(cr)
RT+(cr)(lf)	Return to POS Total	±ddddddd.dE±d(cr) Note 2
RT-(cr)(lf)	Return to NEG Total	±ddddddd.d±d(cr)
RTN(cr)(lf)	Return to NET Total	±ddddddd.d±d(cr)
RTH(cr)(lf)	Return to Total (Heat Quantity)	±ddddddd.d±d(cr)
RTC-(cr)(lf)	Return to Total (Cool Quantity)	±ddddddd.d±d(cr)
RER(cr)(lf)	Return to Energy Transient Quantity	±d.dddddddE±dd(cr)
P	With check return command prefix	Note 5
W	Network command prefix of digit string address	Note 6

Annotations:

- (cr) indicates ENTER, its ASCII code value is ODH. (lf) indicates changing a line and its ASCII code value is OAH.
- “d” indicates 0~9 digits and 0 is expressed by + 0.000000E + 00.
- “d” indicates 0~9 digits and the integral part has no decimal point.
- ddddddd indicates the electronic serial number of the machine.
- Character P could be added before every basic command, it indicates the feedback data has CRC check. The check sum is obtained through binary addition, which is a cumsum binary system taking the least 8-bit binary data.

For example: Feedback information RT(cr)(lf): +1234567E+0m3(cr)(lf)(corresponding binary

data are 2BH, 31H, 32H, 33H, 34H, 35H, 36H, 37H, 45H, 2BH, 30H, 6DH, 33H, 20H, 0DH, 0AH) sum data returned =2BH + 31H + 32H+ 33H + 34H + 35H+ 36H + 37H+45H + 2BH + 30H + 6DH + 33H + 20H = 2F7, and the least 8-bit binary is F7.

Therefore, data of command PRT(cr)(lf) is + 1234567E + 0m3!F7(cr)(lf), "!" as for the delimiter, the first part is the character for summation and the second part is an 1-bit check code.

6. Use of W prefix: W+digit string address code+basic command, the digit string value range is 0~255, divided by 13 (0DH ENTER),10 (0AH changing a line). If you want to access to the transient flow velocity of No. 123 flowmeter, you could send command W123DV (cr) (lf), the corresponding binary codes are 57H, 31H, 32H, 33H, 44H, 56H, 0DH and 0AH; only the meters with the same network address and command could have data feedbacks.
7. W and P commands could be combined for use, for example, W123PRT+, which means the network address it reads is the total value of No. 123 flowmeter, its feedback data are accumulated and checked.

8.3.2. MODBUS-I Communication Protocol

MODBUS-I protocol applies RTU transmission mode, and its check code applies CRC-16-IBM (multinomial is $X^{16}+X^{15}+X^2 + 1$, mask code is 0xA001), which is gained through the cyclic redundancy algorithm.

MODBUS-I RTU mode applies the hexadecimal system to transmit data.

1. MODBUS-I protocol function code and format

Function code	Function data indicated
0x03	Read register
0x06	Single write register

2. Use of MODBUS protocol function code 0x03

Information frame format of the read register sent by the host:

Slave address	Operation function code	Register's first address	Number of registers	Check code
1 byte	1 byte	2 bytes	2 bytes	2 bytes
0x01~ 0xF7	0x03	0x0000 ~ 0xFFFF	X0000 ~ 0x7D	CRC Check code

Slave feedback data frame format:

Slave address	Read operation function code	Number of data bytes	Data	Check code
1 byte	1 byte	1 byte	N*x2 bytes	2 bytes
0x01~ 0xF7	0x03	2xN*	N*x2 data	CRC Check code

N* =Number of data registers.

3. MODBUS protocol function code 0x06

Information frame format of the write-in single register sent by the host (function code 0x06):

Slave address	Operation function code	Register's first address	Number of registers	Check code
1 byte	1 byte	2 bytes	2 bytes	2 bytes
0x01~0xF7	0x06	0x0000~0xFFFF	X0000 ~ 0xFFFF	CRC Check code

Slave feedback data frame format (function code 0x06):

Slave address	Operation function code	Register's first address	Number of registers	Check code
1 byte	1 byte	2 bytes	2 bytes	2 bytes
0x01~0xF7	0x06	0x0000~0xFFFF	X0000~0xFFFF	CRC Check code

Flowmeter's address

Value range is 1~247 (hexadecimal system: 0x01~0xF7), the address could be viewed in Menu 30; if the decimal digit displayed in Menu 30 is 11, the flowmeter's address in MODBUS protocol is: 0x0 B.

The flowmeter's CRC check code is calculated through CRC-16-IBM (multinomial is $X^{16}+X^{15}+X^2 + 1$, mask word is 0xA001) cyclic redundancy algorithms, low byte of the check code is in front, followed by the high byte.

For example, transient flow per hour (m3/h) of the flowmeter with 1 (0x01) read address in RTU mode, i.e. data of two read registers 40005 and 40006, the read commands are shown below:

0x01 0x03 0x00 0x04 0x00 0x02 0x85 0xCA

Flowmeter's address function code/First address register/Number of registers/CRC check code

Flowmeter's feedback data (Assuming the current flow=1.234567m3/h):

0x01 0x03 0x04 0x06 0x51 0x3F 0x9E 0x3B 0x32

Flowmeter's address function code/Number of data bytes/Data/CRC check code

In which, four bytes 3F, 9E, 06 and 51 is 1.2345678, which is the single precision float form in IEEE754 format.

Please pay attention to the order of data in the above example. When explaining the value with C language, you could use the pointer to directly input the data required to related address of variable, the common storage order in general is that the low byte is in front. Taking the above 1.2345678m/s example, the storage order of 3F, 9E, 06 and 51 data is 51, 06, 9E and 3F. For example, in RTU mode, alter the address of flowmeter 1 (0x01) to 2 (0x02), i.e. write the data of

44100 register in 0x02,

Write-in commands are shown below:

0x01 0x06 0x10 0x03 0x00 0x02 0xFC 0xCB

Flowmeter's address function code/Register address/Number of registers/ CRC check code

Flowmeter's feedback data:

0x01 0x06 0x10 0x03 0x00 0x02 0xFC 0xCB

Flowmeter's address function code/Register address/Number of registers/CRC check code

4. Error processing

The flowmeter only returns the error code 0x02, it indicates that the first address of data is wrong.

For example, when it only reads 40002 register data with address 1 (0x01) in RTU mode, the meter would consider that the data integrity is destroyed, so it sends the following commands:

0x01 0x03 0x00 0x01 0x00 0x01 0xD5 0xCA

Flowmeter's address function code/Register address/Number of registers/CRC check code

The flowmeter returns the following error code:

0x01 0x83 0x02 0xC0 0xF1

Flowmeter's address/Error code/Error extension code/CRC check code

5. Address list of MODBUS register

The flowmeter's MODBUS register only includes read-only register and single write-in register.

a) Address list of read-only register (use 0x03 function code to read)

PDU Address	Address	Register	Type	Number	Note
\$0000	40001	Flow/s-low word	32 bits real	2	
\$0001	40002	Flow/s-highword			
\$0002	40003	Flow/m-low word	32 bits real	2	
\$0003	40004	Flow/m-highword			
\$0004	40005	Flow/h-low word	32 bits real	2	
\$0005	40006	Flow/h-highword			
\$0006	40007	Velocity -low word	32 bits real	2	
\$0007	40008	Velocity -highword			
\$0008	40009	Positive total-low word	32 bits real	2	
\$0009	40010	Positive total-highword			
\$000A	40011	Positive total - exponent	16 bits int.	1	
\$000B	40012	Negative total-low word	32 bits real	2	
\$000C	40013	Negative total-highword			

\$000D	40014	Negative total – exponent	16 bits int.	1	
\$000E	40015	NET Total-low word	32 bits real	2	
\$000F	40016	NET Total –high word			
\$0010	40017	NET Total –exponent	16 bits int.	2	
\$0011	40018	Energy flow –low word	32 bits real	2	
\$0012	40019	Energy flow – high word			
\$0013	40020	Energy total(hot) –low word	32 bits real	2	
\$0014	40021	Energy total(hot) – high word			
\$0015	40022	Energy total(hot) –exponent	16 bits int.	1	
\$0016	40023	Energy total(cold) –low word	32 bits real	2	
\$0017	40024	Energy total(cold) – high word			
\$0018	40025	Energy total(cold) –exponent	16 bits int.	1	
\$0019	40026	Upstream signal –low word	32 bits real	2	0-99.9
\$001A	40027	Upstream signal –high word			
\$001B	40028	Downstream signal - low word	32 bits real	2	0-99.9
\$001C	40029	Downstream signal - high word			
\$001D	40030	Signal quality	16 bits int.	1	0~99
\$001E	40031	Error code- Character1	String	1	Refer to "Error Analysis" for detailed codes meanings.
\$003B	40060	Flow velocity unit – Char1,2	String	2	Only m/s right now
\$003C	40061	Flow velocity unit – Char3,4			
\$003D	40062	Flow rate unit-Char1,2	String	2	Note 1
\$003E	40063	Flow rate unit-Char 3,4			
\$003F	40064	Flow total unit-Char1,2	String	1	
\$0040	40065	Energy rate unit-Char1,2	String	2	Note 2
\$0041	40066	Energy rate unit-Char 3,4			
\$0042	40067	Energy total unit-Char1,2	String	1	
\$0043	40068	Instr. Address –low word	32 bits int.	2	
\$0044	40069	Instr. Address – high word			
\$0045	40070	Serial No.-Char 1,2	String	2	
\$0046	40071	Serial No.-Char3,4			
\$0047	40072	Serial No.-Char5,6	String	2	
\$0048	40073	Serial No.-Char7,8			
\$004d	40078	4~20mA value- low word	32 bits real	2	Unit: mA
\$004e	40079	4~20mA value- high word			

b) Address list of single write register (Writing with 0x06 function codes)

PDU add.	Register	Data	Read/Write	Data Type	No. of Registers
\$1003	44100	Flowemeter add. (1-255)	R/W	16 bits	1
\$1004	44101	Communication Baud Rate 0 = 2400,1 = 4800, 2 = 9600, 3 = 19200, 4 = 38400,5 = 56000	R/W	16 bits	1

1. Acceptable flow units:

0."m3"- Cubic Meter

1. "l" -Litre

2."ga"-Gallon

3."ig"-Imperial Gallons

4."mg"-Million Gallons

5."cf"- Cubit Feet

6. "ba"- US Barrel

7."ib"-Imperial Barrels

8."ob"- Oil Barrel

2. Acceptable unit cold (heat) units:

0."GJ"-Giga Joule

1."Kc"-Kilocalorie

2."MB"- MBtu

3."KJ"-Kilojoule

4."Bt" - Btu

5, "Ts"-US Tonnes

6."Tn"-US Tons

7."kw" –Kwh

16 bits int-indicates short integer, 32 bits int-indicates long integer,

32 bits real-indicates floating point number, String-indicates character string.

Appendix. Related Measurement Database

Acoustic velocity of common pipes

Pipe Material	Acoustic Velocity (m/s)	Liner Material	Acoustic Velocity (m/s)
Steel	3206	Teflon	1225
ABS	2286	Titanium	3150
Aluminium	3048	Cement	4190
Brass	2270	Asphalt	2540
Cast iron	2460	Enamel	2540
Bronze	2270	Glass	5970
Fiber reinforced plastics	3430	Plastics	2280
Glass	3276	Polyethylene	1600
Polyethylene	1950	PTFE	1450
PVC	2540	Rubber	1600

If you want to measure or refer to the acoustic velocity of other fluids or materials, please contact the manufacturer.