

**LONGRUN**

**ULTRASONIC  
FLOWMETER  
USER MANUAL**

**TYPE: LRF-6000H**  
Concentrating on Flow  
Measurement

Revision: 1.0.0

UpdateRecord: August, 2020

## Notice!

Thank you for choosing model LRF-6000H Portable Ultrasonic Flowmeter.

This instruction manual contains the important using and operation information of the flow meter. Please read carefully the reference manual before operations to make your portable ultrasonic flowmeter exert the best performance.

If the operation is wrong, it will affect the normal operation of the flow meter, reduce the service life of it or cause some malfunctions.

This manual will present how to use the flow meter step by step. Beginning with the product component, installation, wiring, quick setting and so on which will let you very easily operate the flow meter.

By knowing more menu settings, the powerful function options and output functions of the flow meter can meet your higher requirements.



**Note:** Some content in this manual may be different from the flow meter you purchased, depending on the optional configuration requirements at the time of purchase. On the other hand, due to the design changes and upgrade needs of the product, there is no indication in the manual. Please pay attention to the version number and the added Attached page description.

# Product Component

Inspection should be made before installing. Check if the spare parts are in accordance with the packing list. Make sure that there is no potential damage to the enclosure due to a loose screw or loose wire during transportation. Any questions, please contact your representative as soon as possible.

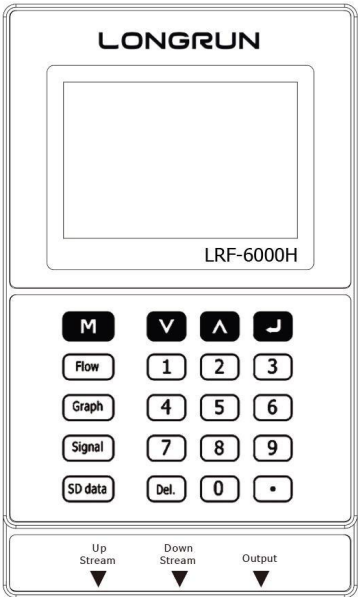
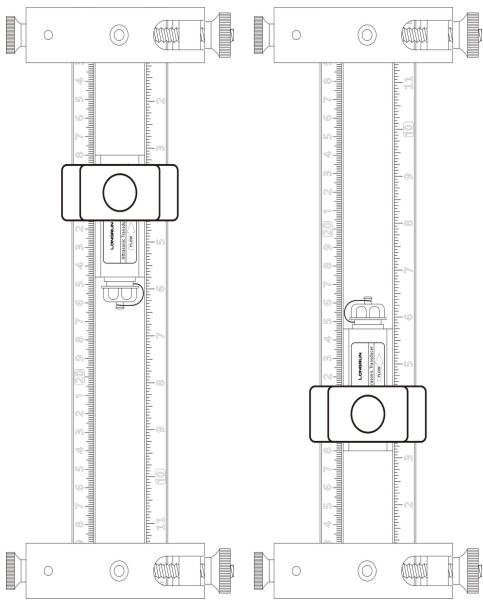
<p style="text-align: center;"><b>Transmitter</b></p> 	<p style="text-align: center;"><b>Transducers with Rack</b></p> 
<p><b>Accessories:</b></p> <ul style="list-style-type: none"> <li>➤ Case</li> <li>➤ Coupling compound</li> <li>➤ Battery changer</li> <li>➤ 4~20mA Wire</li> <li>➤ Transducer cable</li> <li>➤ Flexible rule</li> <li>➤ SD card</li> <li>➤ SD card reader</li> </ul>	<p><b>Documents:</b></p> <ul style="list-style-type: none"> <li>➤ Instruction Manual</li> <li>➤ Certified 3-point factory calibration</li> </ul>

# Content

<b>Transmitter Installation</b> .....	<b>6</b>
Powering On.....	7
Keypad Operation.....	7
<b>Main screen</b> .....	<b>8</b>
<b>Setup Menu</b> .....	<b>10</b>
Setup Menu – Measurement Parameter.....	10
Setup Menu – System Setting.....	11
Setup Menu – Calibration.....	13
Setup Menu – Output Setting.....	15
Setup Menu – Energy Setting .....	17
Setup Menu – Historical Data.....	17
Setup Menu – System Information.....	18
Setup Menu – Manual Totalizer.....	18
Setup Menu – Flow Batch Controller (For wall mount model).....	19
Setup Menu – Language Setting.....	19
<b>Measurement Site Selection</b> .....	<b>20</b>
<b>Transducer Installation</b> .....	<b>21</b>
Transducer spacing.....	21
Transducer Mounting Methods.....	21
V Method.....	22
Z Method.....	22
N Method (not commonly used).....	23
W Method (rarely used).....	23
Transducer Mounting Inspection.....	24
Signal Strength.....	24
Signal Quality (SQ value).....	24
Total Time and Delta Time.....	24
Transit Time Ratio.....	25
<b>Operating Instructions</b> .....	<b>26</b>
Zero Cut.....	26

---

<b>Zero Setting</b> .....	26
<b>Scale Factor</b> .....	26
<b>System Lock (Unlock)</b> .....	26
<b>4~20mA Current Loop calibration</b> .....	27
<b>Analog Output Calibration</b> .....	27
<b>ESN</b> .....	27
<b>Appendix Error Codes and Solutions</b> .....	28

# Transmitter Installation

Take out the transmitter. Shown from left to right on the top of model 6000H are the upstream transducer connector, downstream transducer connector, and 4~20mA output connector.

On the left side of the transmitter, are the power recharging and the power switch.

One rechargeable 11.1V Lithium battery and matching battery charger are coming with.

Please refer to the below diagram for specific connection information:

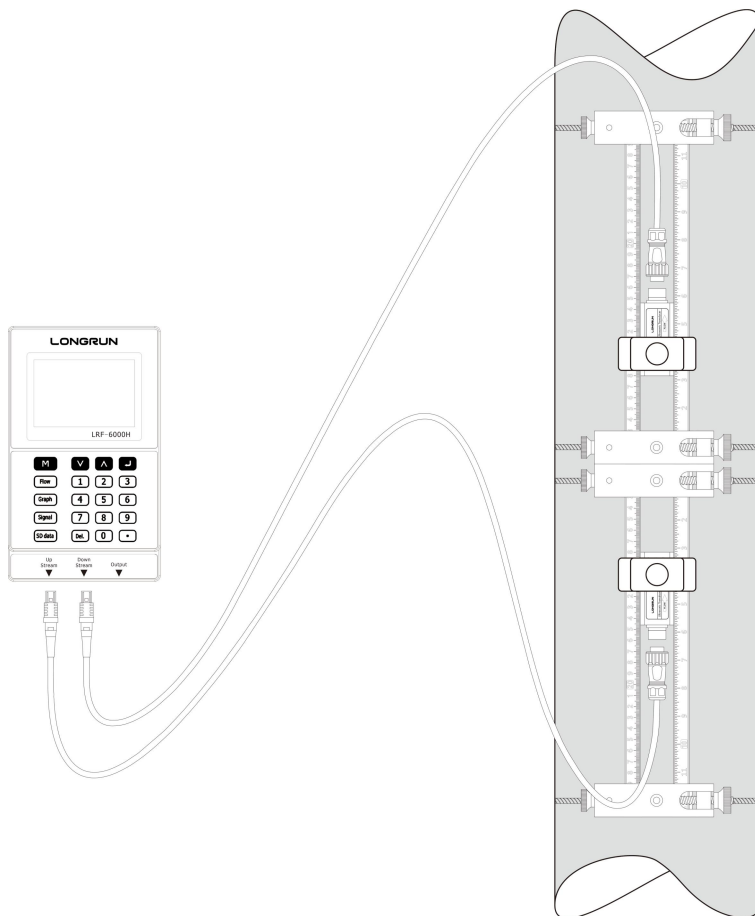

## Caution

Wire when it is power-off. The flow meter must be grounded reliably before installation and use.

## Powering On

When power on, the self-diagnosis program will start to run. If any error is detected, an error code will be displayed on the screen (see Error Codes and Solutions). After that, the system will run automatically using the programmed parameters.

If it is the first time to use or install on a new site, new installation site parameters are needed to enter. Any parameters which are set by the user will be saved permanently until next change.

When the user reedits the parameters or removes the transducers, the flow meter will recalculate automatically, and operate normally with the newly set parameters.

## Keypad Operation

Follow these guidelines when using the Flowmeter keypad:

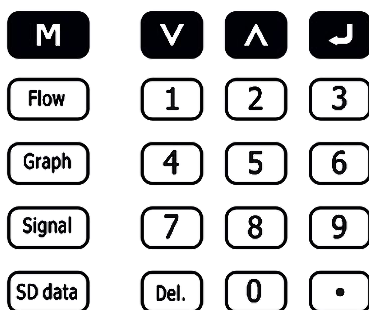

**M** for setting and display mode, when in setting mode, press it to turn to previous menu, **↑** and **↓** for scrolling up and down to select the menu, when press **↓** to move to next digit, press **↑** and the numbers scroll from 0 to 9. Select them. Press **↩** to confirm, press **Del.** to delete.

**Flow** For displaying flow rate and totalize; **Graph** For displaying flow rate curve;

**Signal** For displaying signal diagnosis information; **SD data** For SD card data collection operation.

## Main screen



When power on, the self-diagnosis program will automatically start to run. First comes the welcome screen:

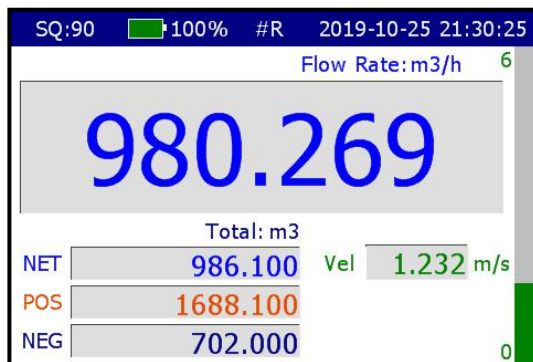

Signal Quality (SQ value), Net Totalizer (NET), Positive Totalizer (POS), Negative Totalizer (NEG), Flow Velocity (Vel).

**Note: SQ value is short for Signal Quality. It indicates the level of the signal detected. SQ value is indicated by numbers from 0~99. 00 represents the minimum signal detected while 99 represent the maximum.**



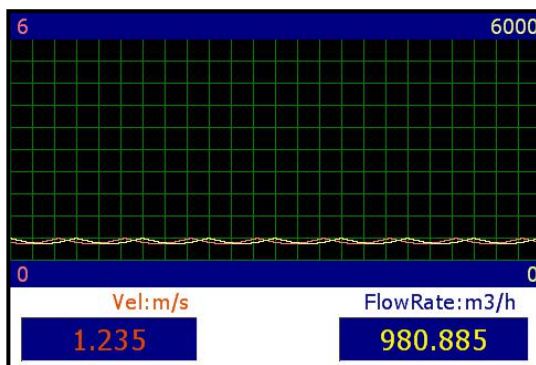

Display the velocity and flow curve. The data will be updated only stay in this screen.



Display the signal strength, Date and time, Signal quality, Speed ratio (TOM/TOS), Sound Velocity, Total transit time (TOF), Delta time (DT).

About TOM/TOS: Display the ratio of actual measured transmission time to calculated transmission time according to customer requirements. Normally the ratio should be 100±3%. If the difference is too large, the user should check that if the parameters are entered correctly, especially the sound velocity of the fluid and the installation of the transducers.

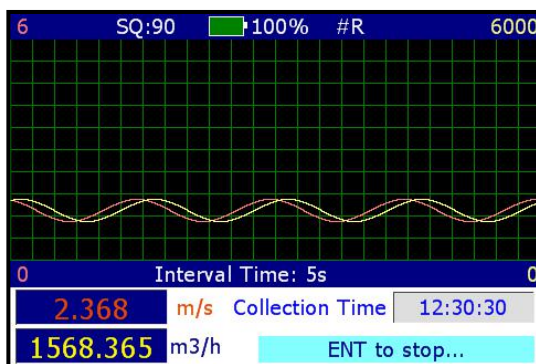

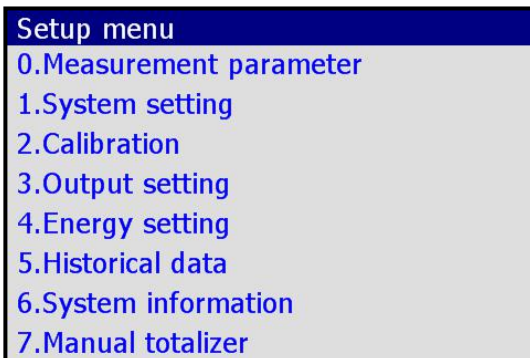

Display the signal strength, flow rate, flow totalizer and collection time. Press ENT to choose stop or continue, Double-click ENT to stop data collection, Flow data will be stored on the SD card. Cannot any operation when the meter run collection, once it exits, the collection is stop.

# Setup Menu



Press **M** will display Setup menu.

The following options are available (by pressing  or  buttons), select the option

## Setup Menu – Measurement parameter

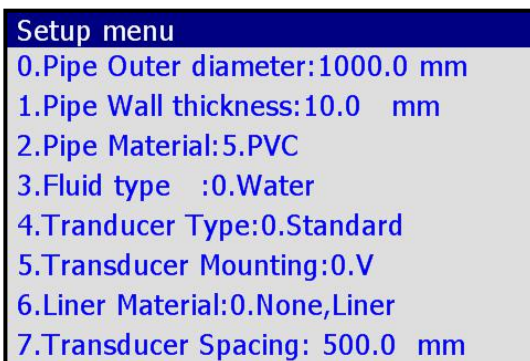

For example, to measure a DN1000 PVC pipe with medium as water and no liner. Input settings are as above.

When finish entering parameters and selections, the flow meter will display transducer spacing, then we can install the transducers.

0. Pipe Outer diameter range: 25~6000mm

1. Pipe Wall thickness range: 0~600mm

2. Pipe material:

0. Carbon Steel

1. Stainless Steel

2. Cast Iron

3. Ductile Iron

4. Copper

5. PVC

6. Aluminum

7. Asbestos

8. Fiber Glass Epoxy

9. Other

3. Fluid type:

- |              |              |            |
|--------------|--------------|------------|
| 0. Water     | 3. Gasoline  | 6. Propane |
| 1. Sea Water | 4. Fuel Oil  | 7. Butane  |
| 2. Kerosene  | 5. Crude Oil | 8. Other   |

4. Transducer Type:

- 0. Standard
- 1. Wetted45
- 2. Wetted23

5. Transducer installing:

- |             |             |
|-------------|-------------|
| 0. V Method | 2. N Method |
| 1. Z Method | 3. W Method |

6. Liner Material:

- |                |                  |                 |
|----------------|------------------|-----------------|
| 0. None, Liner | 4. Polypropylene | 8. Polyethylene |
| 1. Tar Epoxy   | 5. Polystyrol    | 9. Ebonite      |
| 2. Rubber      | 6. Polystyrene   | 10. Teflon      |
| 3. Mortar      | 7. Polyester     | 11. Other       |

7. Transducer Spacing: calculated automatically by the flow meter instead of manual selection.

**Setup Menu – System setting**

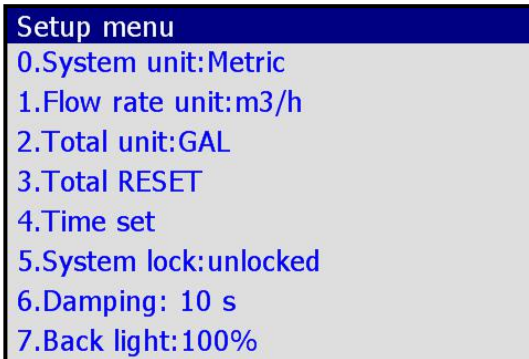

0. System unit: select the measurement unit as follows: (Factory default is metric)

- 0. Metric
- 1. English

1. Flow rate: the following flow rate units are available: (day, hour, min, sec)

- |        |       |        |
|--------|-------|--------|
| 0. m3  | 3. ig | 6. bal |
| 1. L   | 4. mg | 7. ib  |
| 2. GAL | 5. cf | 8. ob  |

2. The following units are available:

0. m3	3. IG	6. UB
1. L	4. mg	7. IB
2. GAL	5. cf	8. OB

3. Total RESET:

ENT TO RESET: reset all totalizer

System RESET: factory reset

**Note: Except during the initial installation, it is generally not necessary to activate this feature.**

4. Time set:

Generally, it is unnecessary to modify date time as the system is provided with a highly reliable perpetual calendar chip.

The format for time setting is 24-hour.

5. System lock:

System lock is readable but uneditable to prevent operation error due to unauthorized tampering.

6. Damping:

The damping function will stabilize the flow displaying. Essentially, it is a part of the signal filter. Enter the coefficient and increase it to improve stability. However, due to over-damping, the displayed measurement may be slightly delayed. The measurement time is too long, especially when the flow fluctuates greatly, and there is no response to real-time fluctuations. Therefore, the damping should be kept to a minimum and increased just enough to reduce the fluctuation to an acceptable level for 3 to 10 seconds.

The damping coefficient is between 0~999 seconds. 00 means no damping; 999 means maximum damping. In applications, a damping factor of 3~10 is usually recommended.

7. Back light:

Brightness is adjustable between 5% to 100%

## Setup Menu – Calibration

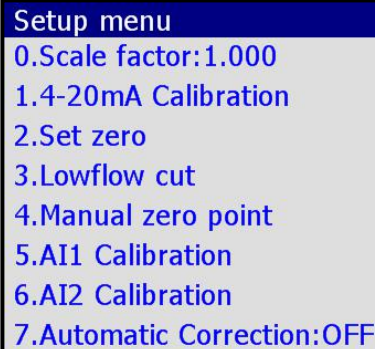

Setup menu  
0.Scale factor:1.000  
1.4-20mA Calibration  
2.Set zero  
3.Lowflow cut  
4.Manual zero point  
5.AI1 Calibration  
6.AI2 Calibration  
7.Automatic Correction:OFF

### 0. Scale factor:

Scale factor refers to the ratio between “actual value” and “reading value”. For example, when the measurement is 2.00, and it is indicated at 1.98 on the instrument, the scale factor reading is 2/1.98. This means that the best scale factor constant is 1.

During operation, there still exists possible difference in pipe parameters, etc. The “scale factor” may be necessary when use on different pipes. Thus, scale factor calibration is specially designed for calibrating the differences that result from applications on different pipes. The scale factor entered must be one that results from actual calibration.

### 1. 4-20mA Calibration:

Check if the current loop has been calibrated before leaving factory.

Select 4mA, and at the same time check with an ammeter to verify that output terminals agree with the displayed values. It is necessary to re-calibrate the current loop if it display over the permitted tolerance.

20mA calibration is with the same method.

**Note: When verifying the current loop, make sure the flow meter has run for more than 20 minutes.**

### 2. Set zero:

When the fluid is in the static state, the displayed value is called “Zero Point”. When “Zero Point” is not at zero in the flow meter, the difference is going to be added into the actual flow values and measurement differences will occur in the flow meter.

Set zero must be carried out after the transducers are installed and the flow inside the pipe is in the absolute static state (no liquid movement in the pipe). Thus, the “Zero Point” resulting from different pipe mounting locations and parameters can be eliminated. The measuring accuracy at low flow is enhanced by doing this and flow offset is eliminated.

### 3. Low flow cut:

If the flow rate falls below the low flow cutoff value, the flow indication is driven to zero. This function can prevent the flow meter from reading flow after a pump as shut down but there is still liquid movement in the pipe, which will result in tantalization error.

Generally, 0.03m/s is recommended to enter as the low flow cutoff point. The low flow cutoff value has no relation to the measurement results once the velocity increases over the low flow cutoff value.

4. Manual zero point:

This method is not commonly used. It is only suitable for experienced operators to set zero point under conditions when it is not preferable to use other methods. Enter the value manually to add to the measured value to obtain the actual value.

**For example:**

Actual measured value = 250 m<sup>3</sup>/h

Value Deviation = -10 m<sup>3</sup>/h

Flow meter Display = 240 m<sup>3</sup>/h

Normally, set the value as "0".

5. AI1 Calibration: (For wall mount models)

Calibration analog input channel 1.

6. AI2 Calibration: (For wall mount models)

Calibration analog input channel 2.

7. Automatic Correction:

With the function of automatic flow correction, the flow lost in an offline session can be estimated and automatically adjusted. The estimated value is based on the average value multiplied by the time period during which the meter is offline. The average value is derived from the flow before the offline and the flow measured after the offline. Select "No" to cancel this function.

8. Linear correction:

Sometimes there is a small deviation between the flow model and the actual measured value. In order to make the measured value more closed to reality, the flow data can be corrected according to the calibration value.

Up to 16 segments can be corrected according to the flow rate.

## Setup Menu – Output setting

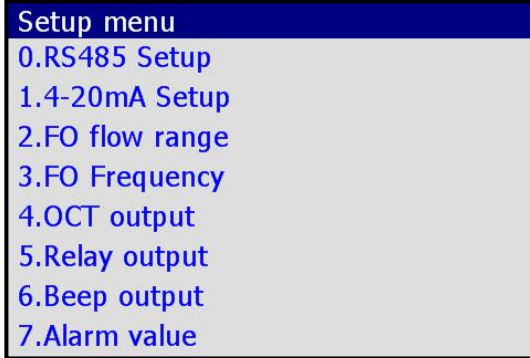

### 0. RS485 Setup:

The window used to set serial ports. It's for communications with other equipment. It connects with the equipment through serial ports. The parameters must be set to match with each other. Select the baud rate 9600, 19200, 38400, 56000, 57600, 115200. The second option is that in check, None.

Data length is fixed to 8

Fixed length stop bit

Default serial port parameters: 9600, 8, None, 1

### 1. 4-20mA Setup:

0. 4mA value: Set the CL output value according to the flow value

1. 20mA value: Set the CL output value according to the flow value

2. CL mode: Select the current loop mode

- |                     |  |
|---------------------|--|
| 0. 4-20mA           | Set up the output range from 4-20mA    |
| 1. 20-4-20mA        | Set up the output range from 20-4-20mA |
| 2. 4-20mA vs Vel.   | Set up the CL output range from 4-20mA |
| 3. 4-20mA vs Energy | Set up the CL output range from 4-20mA |

### 2. FO flow range: (For wall mount models)

Set up FO flow rate, which is the corresponding flow value when output signal frequency is at the lowest or Highest FO frequency.

### 3. FO Frequency: (For wall mount models)

Set up low FO frequency and high FO frequency range.

### 4. OCT output: (For wall mount models)

The OCT output in the flow meter is a kind of isolated collector open circuit output with programmable open and close qualifications. The user can program the open and close functions under the following conditions: the system alarm signals are being activated or the totalizer pulse is being transmitted.

The frequency output signal is also transmitted from the OCT. When it functions as the

frequency output, other functions are unavailable.

The following signal options are available:

- |                  |                  |              |
|------------------|------------------|--------------|
| 0. No Signal     | 4. POS Int Pulse | 8. FO        |
| 1. Alarm #1      | 5. NEG Int Pulse | 9. Not Using |
| 2. Alarm #2      | 6. NET Int Pulse |              |
| 3. Batch Control | 7. Energy Pulse  |              |

Note: 3 and 7 is optional.

5. Relay output: (For wall mount models)

The relay output in the flow meter is programmable. The user can program the open and close functions under the following conditions, the system alarm signals are activated or the Totalizer pulse is transmitting. The relay is single-pole and constant-on for external flow meter controls.

The following signal options are available:

- |              |                  |                  |
|--------------|------------------|------------------|
| 0. No Signal | 3. Batch Control | 6. NET Int Pulse |
| 1. Alarm #1  | 4. POS Int Pulse | 7. Energy Pulse  |
| 2. Alarm #2  | 5. NEG Int Pulse | 8. Not Using     |

Note: 3 and 7 is optional.

6. Beep output: (For wall mount models)

The beep output in the flow meter is programmable. The user can program the open and close functions under the following conditions.

The following signal options are available:

- |                  |                  |              |
|------------------|------------------|--------------|
| 0. No Signal     | 4. POS Int Pulse | 8. KEY input |
| 1. Alarm #1      | 5. NEG Int Pulse | 9. Not Using |
| 2. Alarm #2      | 6. NET Int Pulse |              |
| 3. Batch Control | 7. Energy Pulse  |              |

Note: 3 and 7 are optional.

7. Alarm value: (For wall mount models)

Enter the low and high alarm value. Both relevant alarms are on OCT output; any of the measured flow, which is lower or higher than the alarm value will activate the alarm in the OCT hardware or relay output signal.

8. AI range: (For wall mount models)

Analog input range: 0-9999

Enter range value which 4mA and 20mA analog input represented.

9. Output Multiplier:

Select pulse output multiplier.



## Setup Menu – Energy setting

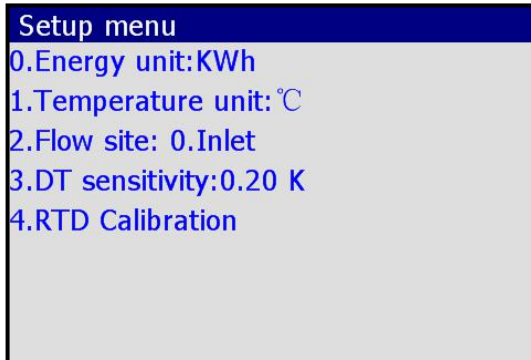

0. Energy unit:

- 0. GJ
- 1. MBtu
- 2. KWh
- 3. MWh
- 4. RT

1. Temperature unit:

- 0. °C
- 1. °F

2. Flow site:

- 0. Inlet
- 1. Outlet

## Setup Menu – Historical data

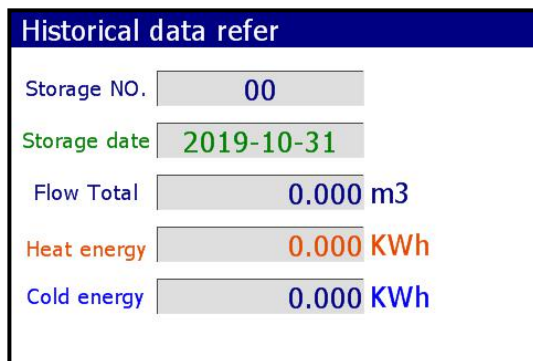

Review the historical flow data totalizer for any day in the last 64 days, any month in last 64 months and any year in the last 10 years.

## Setup Menu – System information

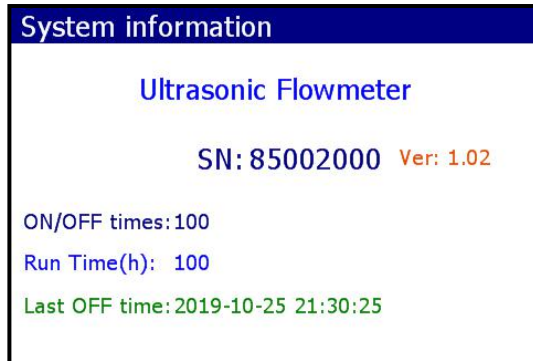

Display electronic serial number (ESN) of the flow meter, power on/off time, run time and flow rate.

This ESN is the only one assigned to each flow meter when ready to leave factory.

## Setup Menu – Manual totalizer

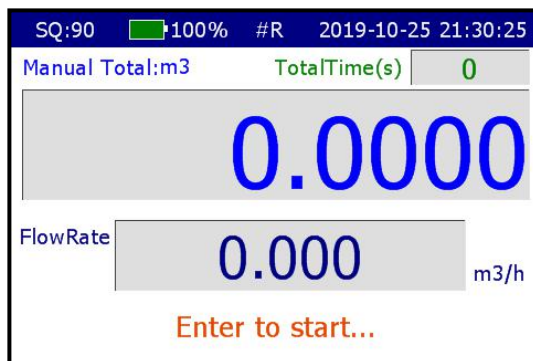

The manual totalizer is a separate totalizer. Press



to start, and press again to stop it. It is used for flow measurement and calculation.

**Setup Menu – Flow Batch controller (For wall mount model)**

```
Setup menu
FlowBatch Controller
0.Flow Batch CTRL by:0.Key Input
1.Flow Batch Total:1000 m3
2.Key Input:OFF 0.0 m3
```

Batch control can be carried out, and the total amount can be controlled and operated by button setting.

**Setup Menu – Language setting**

```
Setup menu
Language setting
0.English
1.Chinese Simplified
2.Chinese Traditional
```

Language setting: 0. English; 1. Chinese Simplified; 2. Chinese Traditional

# Measurement Site Selection

When selecting a measurement site, it is important to select an area where the fluid flow profile is fully developed to guarantee a highly accurate measurement. Please follow these guidelines for selecting a proper measurement installation site:

Choose a section of pipe, which is always full of liquid, such as a vertical pipe with flow in the upward direction or a full horizontal pipe.

Make sure that the pipe surface temperature at the measuring point is within the transducer temperature limits.

Consider the inside condition of the pipe carefully. If possible, select a section of pipe where its inside is free excessive corrosion or scaling.

Examples acceptable measurement site selection are shown in the figure below.

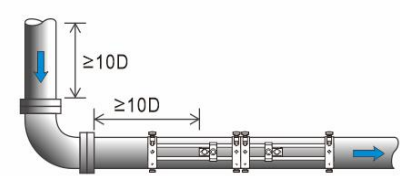
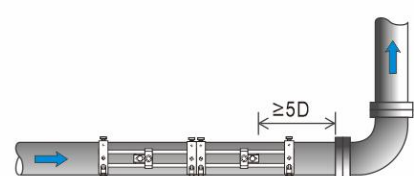
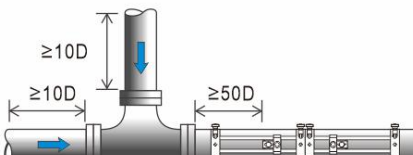
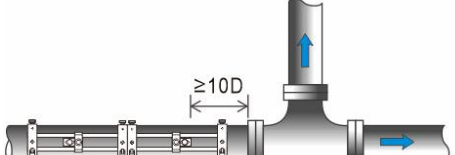
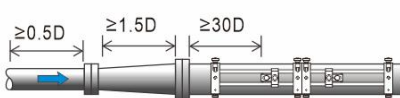
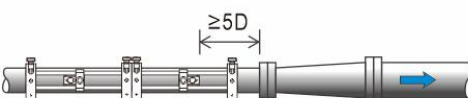
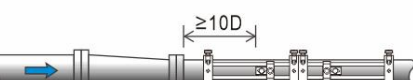
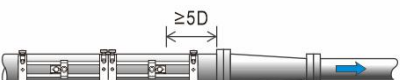
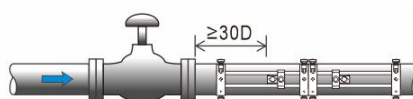
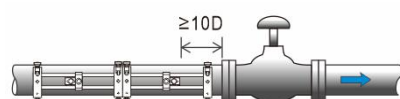
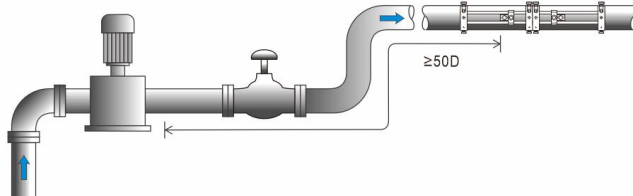
Site	Installation point front straight section	Straight pipe section after installation point
Elbow		
Tee		
Expanded pipes		
Reducing pipe		
Valve		
Pump		

## Transducer Installation

Before installing the transducers, clean the pipe surface where the transducers are to be mounted. Remove any rust, scale or loose paint and make a smooth surface. Choose a section of sound conducting pipe for installing the transducers. Apply a wide band of sonic coupling compound down the center of the face of each transducer as well as on the pipe surface, and then attach the transducers to the pipe with the provided racks and tighten them firmly.

### Note:

The two transducers should be installed at the pipe's centerline of horizontal pipeline.

Make sure that the transducer installation direction is parallel with the flow.

During the installation, there should be no air bubbles or particles between the transducer and the pipe surface. On horizontal pipes, the transducers should be installed in the 3 o'clock and 9 o'clock positions of the pipe section in order to avoid any air bubbles inside the top portion of the pipe. If the transducers cannot be installed horizontally symmetrically due to limitation of the real installation conditions, it may be necessary to install the transducers at a location where there is a guarantee full pipe condition (the pipe keeps full of liquid).

## Transducer spacing

After entering the required parameters, the spacing between the tops of the two transducers is considered as the standard transducer spacing. Check the data displayed in "Setup Menu – Pipe parameter" and reserve the spacing for the transducers' installation.

## Transducer Mounting Methods

Four transducers installation methods are available: V method, Z method, N method and W method. The V method is mainly used for small diameter pipelines (25mm~400mm, 1"~16"). The Z method is used in applications where the V method cannot work due to poor signal or no signal detected. In addition, the Z method usually works better on larger diameter pipes (larger than 300mm, 12") or cast iron pipes. The N method and the W method are not commonly used methods. They are used for smaller diameter pipes (less than 50 mm, 2").

V Method

The V method is considered as the standard method. It usually gives a more accurate reading and is used on pipe diameters from 25mm to 400mm (1" ~16"). It is convenient to install, but still requires proper installation of the transducers. It is in contact with the pipeline at the centerline of the pipeline, and the spacing on both sides of the centerline is equal.

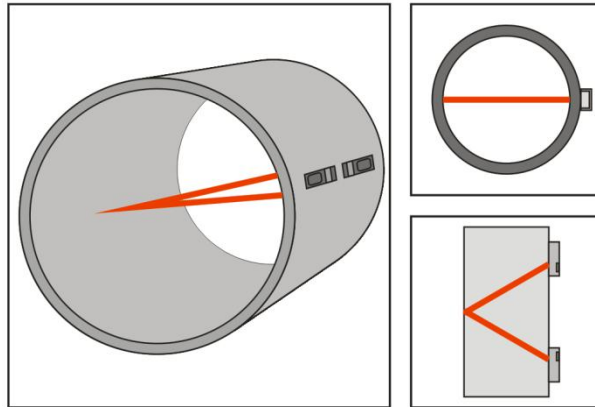

Z Method

The signal transmitted with Z method installation gets less attenuation than a signal transmitted with the V method. This is because the Z method utilizes a directly transmitted (instead of reflected) signaling which transverses the liquid only once.

The Z method is able to measure pipe diameters from 100mm to 3000mm (4" ~120"). Therefore, we recommend the Z method for pipe diameters over (300mm 12").

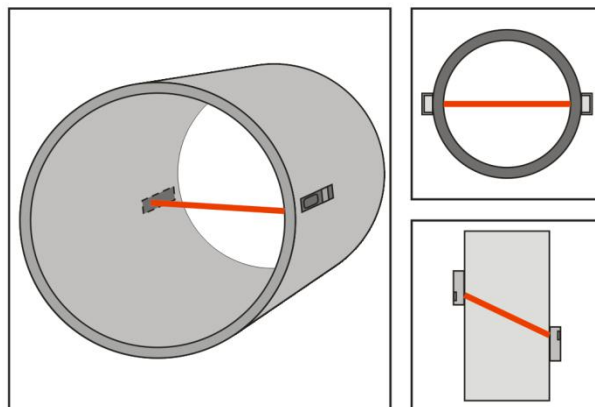

**N Method (not commonly used)**

With the N method, the sound waves traverse the fluid twice and bounce three times off the pipe walls. It is suitable for small pipe diameter measurement.

The measurement accuracy can be improved by extending the transit distance with the N method (commonly used).

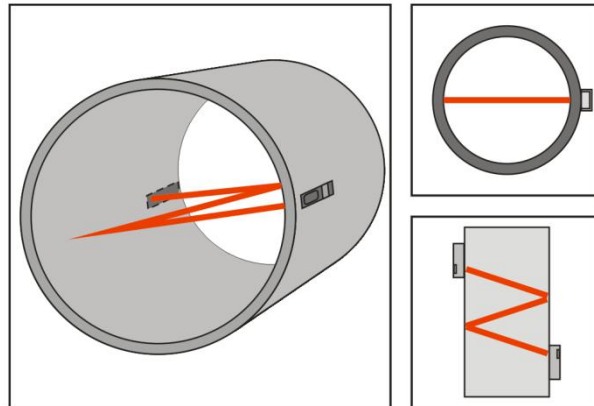

**W Method (rarely used)**

As with the N method, the measurement accuracy can also be improved by extending the transit distance with the W method. The sound wave traverses the fluid four times and bounces four times off the pipe walls. It is suitable for very small pipe (diameter less than 50mm, 2”).

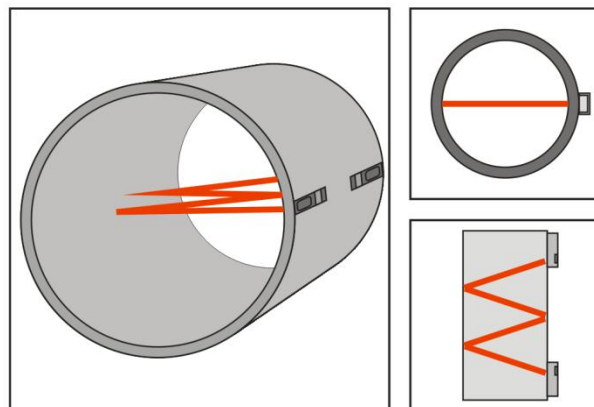

## Transducer Mounting Inspection

Check if the transducers are installed properly and accurate and strong enough ultrasonic signal to make sure proper operation and high reliability of the transducers. Confirm them by checking the detected signal strength, total transit time, delta time and transit time ratio.

The installation condition directly influences the flow value accuracy and system long-time running reliability. In most cases, only need to fix the transducers on the pipe section to get good measurement results. However, in order to ensure high reliability of measurement and long-term operation of the flow meter, the following checks are still required.

### Signal Strength

Signal strength indicates a detected strength of the signal both from upstream and downstream directions. The relevant signal strength is indicated by numbers from 00.0~99.9. 00 represents no signal detected while 99 represent maximum signal strength.

Normally, the stronger the signal strength detected, the longer the operation of the flow meter reliably, as well as the more stable the measurement value obtained.

Adjust the transducers to the best position and check to ensure that enough sonic coupling compounds is applied adequately during installation in order to obtain the maximum signal strength.

Measuring system normally requires signal strength reach over 60, which is detected from both upstream and downstream directions. If the signal strength detected is too low, the transducer installation positions and the transducer mounting spacing should be re-adjusted and the pipe should be re-inspected. If necessary, change to the Z installation method.

### Signal Quality (SQ value)

SQ value is the abbreviation for signal quality, and it represents the detected signal quality. The SQ value is represented by a number between 00 and 99. 00 represents the worst signal detected, and 99 represents the best signal quality.

Generally, the position of the transducers should be adjusted frequently and the use of the coupling should be checked frequently until the detected signal quality is as strong as possible.

### Total Time and Delta Time

“Total Time and Delta Time”, which displays in “Main Menu”, indicating the condition of the installation. The measurement calculations in the flow meter are based upon these two parameters. Therefore, when “Delta Time” fluctuates largely, the flow and velocities fluctuate as well. This means that the signal quality detected is too poor. It may be the results of mis-installation method, terrible installation sites or incorrect parameter entered.

Generally, fluctuation of “Delta Time” should be less than  $\pm 20\%$ . Only when the pipe diameter is too small or too slow flow rate could the fluctuation be larger.



## Transit Time Ratio

Transit Time Ratio indicates if the transducer mounting spacing is accurate. The normal transit time ratio should be  $100\pm 3$  if the installation is proper. Check it in “Main Menu”.



If the transit time ratio is over  $100\pm 3$ , it is necessary to check:

- (1) If the parameters (pipe outside diameter, wall thickness, pipe material, liner, etc.) have been set correctly,
- (2) If the transducer mounting spacing is accordance with the display in “Setup Menu – Pipe parameter”,
- (3) If the transducer is mounted at the pipe’s centerline on the same diameter,
- (4) If the scale is too thick or the pipe mounting is distorted in shape, etc.

## Cautions!

- (1) Pipe parameters entered must be accurate; otherwise the flow meter will not measure accurately.
- (2) During the installation, apply enough coupling compounds in order to stick the transducers onto the pipe surface. While checking the signal strength and SQ value, move the transducers slowly around the mounting site until the strongest signal and maximum SQ value can be obtained. Note that the larger the pipe diameter, the more the transducer should be moved.
- (3) Pay special attention to those pipes with seams, since such pipes are always irregular. If the signal strength is always displayed as 0.00, that means there is no signal detected. Thus, it is necessary to check that the parameters (including all the pipe parameters) have been entered accurately. Check to be sure the transducer mounting method has been selected properly, the pipe is not worn-out, and the liner is not too thick. Make sure there is indeed fluid in the pipe or the transducer is not very close to a valve or elbow, and there are not too many air bubbles in the fluid, etc. With the exception of these reasons, if there is still no signal detected, the measurement site has to be changed.
- (4) Make sure that the flow meter is able to run properly with high reliability. The stronger the signal strength displays, the higher SQ value would reach. The longer the flow meter runs accurately, the higher reliability of the flow rates would show. If there is electromagnetic interference around or the detected signal is too bad, the displayed flow value is unreliable, thus reducing the ability to operate reliably.
- (5) After completed installation, power on the flow meter and check.

# Operating Instructions

## Zero Cut

When static flow with zero flow rate, set a zero point in the flow meter. It is indicated as zero when the measurement flow rate reach to zero. When necessary to establish the true zero flow condition, set it in the flow meter.

## Zero Set

If the zero point is not set based with the static flow, a measurement difference may occur. The smaller the physical measurement capacity is, the bigger the measurement difference from the zero point will be. Only when zero point is reduced to a certain extent, can the measurement difference of the zero point be ignored compared with the physical measurement capability..

For an ultrasonic flow meter, the measurement difference from zero point cannot be ignored at low flow. It is necessary to process a zero-set calibration to improve low flow measurement accuracy.

## Scale Factor

Scale factor refers to the ratio between “actual value” and “reading value”. For example, when the measurement is 2.00, and it is indicated as 1.98 on the flow meter, the scale factor reading is  $2/1.98$ . This means that the best scale factor constant is 1.

However, it is difficult to keep the scale factor as “1” on the flow meter especially in batch operations. The difference is called “consistency”. High consistency are necessary requirements to best flow meters.

The default scale factor is “1” for each flow meter before leaving factory. Since the scale factors in flow meters are only influenced by two parameters: the crystal oscillation frequency and the transducer. While no relation to other circuit parameters.

During operation, there still exists possible difference in pipe parameters, etc. The “scale factor” may be necessary when used on different pipes. Thus, scale factor calibration is specially designed for calibrating the differences that result from applications on different pipes. The scale factor entered must be one that results from actual calibration.

## System Lock (Unlock)

System lock is readable but uneditable to prevent operation error due to unauthorized tampering.

Get to “Setup Menu – System setting” to set a 4-digit password.

Keep the password in mind or record it in a safe place, otherwise the flow meter cannot be used if it is locked and without true password.

## 4~20mA Current Loop Calibration

With a current loop output exceeding 0.5% accuracy, the flow meter is programmable and configurable with multiple output modules such as 4~20mA. Select “Setup Menu – Input and Output setting”

In this window, to calibrate 4mA flow value and 20mA flow value.

For example:

If the flow range is between 0~1000m<sup>3</sup>/h, input 0 and 1000.



If the flow range is from -1000~0~2000m<sup>3</sup>/h, turn to configure the 20~4~20mA module till the flow direction is rectified. input -1000 and 2000.

## Analog Output Calibration



Each flow meter has been calibrated strictly before leaving factory. It is unnecessary to carry through this step except when the current value (detected while calibrating the current loop) displayed in “Setup Menu – Input and output setting” is not identical with the actual output current value.

The hardware detect window must be activated prior to calibration. Procedures are as follow:

Press  and  to calibrate the current loop 4mA output. Use an ammeter to measure the current loop output current. At the same time, press  to adjust the displayed numbers. Stop adjusting when the ammeter reads 4.00. And 4mA Output is set.

Then, press  to calibrate the current loop 20mA output. Same method as it is with 4mA calibration.

These results are saved automatically in EEPROM and will not get lost after power off.

## ESN

We provide the flow meter with a unique electronic serial number to identify each flow meter for the convenience of the manufacturer and customers. The ESN, flow metertypes and versions are able to be viewed in “Setup Menu – System Information”.

# Appendix Error Codes and Solutions

Code	Display	Cause	Solution
#R	System Normal	➤ System normal	➤ No errors
#I	Signal Not Detected	<ul style="list-style-type: none"> <li>➤ Signal not detected</li> <li>➤ Spacing is not correct between the transducers or not enough coupling compound applied to face of transducers.</li> <li>➤ Transducers installed improperly.</li> <li>➤ Scale is too thick.</li> <li>➤ New pipe liner.</li> </ul>	<ul style="list-style-type: none"> <li>➤ Attach transducer to the pipe and tighten it securely. Apply a plenty of coupling compound on transducer and pipe wall.</li> <li>➤ Remove any rust, scale, or loose paint from the pipe surface. Clean it with a file.</li> <li>➤ Check the initial parameter settings.</li> <li>➤ Remove the scale or change the scaled pipe section. Normally, it is possible to change a measurement location. The flow meter may run properly at a new site with less scale.</li> <li>➤ Wait until liners solidified and saturated.</li> </ul>
#G	Adjusting Gain	➤ Adjusting gain for normal measurement.	

# LONGRUN

Longrun Industrial Instrument Co.,Ltd

24hours service:+86-186-5435-6933

Tel:+86-543-3382666

Fax:+86-543-3615999

E-mail:[info@ultrasonicscn.com](mailto:info@ultrasonicscn.com)

Website:[www.longrun-flowmeter.com](http://www.longrun-flowmeter.com)

This instruction is recyclable

